

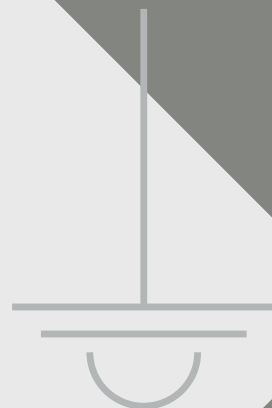

Quadrifoglio Group

# Lighting & Acoustic Collection



# Quadrifoglio Group. Living and breathing design, everywhere

## We are Ethics and Vision in the form of Order and Ergonomics.

Design Office, Living and Lighting. Three ways of exploring design, united by the quality of the materials, the quest for elaborate finishes and the continuous focus on comfort and well-being, as part of an all-Italian identity.

---

Quadrifoglio Group,  
vivere il design, ovunque

**Siamo Etica e Visione declinate  
in Ordine ed Ergonomia.**

Design Office, Living e Lighting. Tre modi di coniugare il design, accomunati dalla qualità dei materiali, dalla ricerca di finiture elaborate e dalla tensione continua al comfort e al benessere, nel segno di un'identità tutta italiana.



# Our Identity

## Strong values, dynamic thinking

Over the years we have seen the world change. Technological, social and cultural innovations, together with climate change, are transforming our lives and the way we inhabit our spaces. The office, the home, public and private spaces are now hybrid environments that demand new design approaches.

In response to these ongoing changes the Quadrifoglio Group has made a pledge: to make design sustainable in order to improve our quality of life. A sense of ethics that pervades all of its actions. From the careful selection of top-quality raw materials through to the expert choice of the most evocative finishes, from the manual actions of its designers, who sketch out their initial ideas on a piece of paper, through to those of the machinery which sculpts it from the material with pinpoint precision.

Quadrifoglio Group, since 1991.

---

## La nostra Identità

### Valori fermi, pensiero dinamico

Nel corso degli anni, abbiamo visto cambiare il mondo. Le innovazioni tecnologiche, sociali e culturali e i cambiamenti climatici stanno trasformando la nostra vita e il modo in cui abitiamo gli spazi. L'ufficio, la casa, i luoghi pubblici e privati sono ormai ibridi e impongono nuove vie di pensiero alla progettazione.

In Quadrifoglio Group interpretiamo questi incessanti mutamenti attraverso un unico impegno: rendere sostenibile il design, per aumentare la qualità della vita. Un rigore etico che pervade ogni gesto. Dalla selezione accurata delle materie prime di assoluta qualità, fino alla scelta sapiente delle finiture più evocative, dal movimento delle mani dei designer, che tracciano su un foglio la prima manifestazione di un'idea, fino a quello del macchinario che con accuratezza millimetrica la scolpisce nella materia.

Quadrifoglio Group, dal 1991.





# People and relations

## Thoughts, ideas, intuition

There would be no places without the people that live there. There would be no design without ideas. There would be no Quadrifoglio Group without our workers, customers and partners.

At the Quadrifoglio Group every project stems from and for interpersonal relations; from the sharing of an idea by designers to the production of ergonomic furniture and through to the design of comfortable spaces perfect for personal interaction. We choose our partners on the basis of shared values. We share with all employees a style of work based on order, both exterior and interior. During the year we dedicate time to training in order to share knowledge and enrich our perspective. Social commitment, company welfare and the protection of personal safety: this is how we put our people at the centre.

Quadrifoglio Group, people first and foremost.

---

## Persone e relazioni

### Pensieri, idee, intuizioni

Non esisterebbero i luoghi senza le persone che li vivono. Non esisterebbe il design senza un'intuizione tra le mani. Non esisteremmo noi, senza i nostri collaboratori, clienti e partner.

In Quadrifoglio Group ogni progetto nasce dall'incontro e per l'incontro tra le persone. Da quando un'idea viene condivisa dai designer, alla produzione di arredi ergonomici, fino alla progettazione di ambienti confortevoli, dove abitare le relazioni. Selezioniamo i nostri partner sulla base di valori comuni. Condividiamo uno stile di lavoro improntato all'ordine, esteriore e interiore, con tutti i dipendenti. Dedichiamo del tempo durante tutto l'anno alla formazione, per contaminare i saperi e arricchire la nostra prospettiva. Impegno sociale, welfare aziendale e tutela della sicurezza: ecco come mettiamo le persone al centro.

Quadrifoglio Group, siamo prima di tutto persone.



# Our commitment

## Sustainability is an everyday action

Sustainability is awareness, vision, transformation. It is the ability to construct the future by taking action in the present, also by changing little things.

At the Quadrifoglio Group we work every day to ensure that Sustainability becomes pervasive: a way of thinking, working and living, to feel good today and even better tomorrow. An ethical value, to share collectively but also to practice individually. Our focus on improving company processes, with respect for the environment, is constant. From the streamlining of production to the attainment of international green certificates, from company welfare policies through to the creation of an open roundtable with our team dedicated to sustainability, in order to share goals and strategies. This is our commitment.

Quadrifoglio Group, informed ethics.

---

## Il nostro impegno

### La Sostenibilità è un atto quotidiano

La Sostenibilità è consapevolezza, visione, trasformazione. È la capacità di costruire il futuro agendo nel presente, anche attraverso piccoli gesti.

In Quadrifoglio Group ci impegniamo ogni giorno affinché la Sostenibilità diventi pervasiva: un modo di pensare, di lavorare e di vivere, per stare bene oggi e meglio domani. Un valore etico, da condividere collettivamente e da praticare anche individualmente. La nostra tensione verso il miglioramento dei processi aziendali, nel rispetto dell'ambiente, è costante. Dalla razionalizzazione della produzione, all'ottenimento delle certificazioni green internazionali, dalle politiche di welfare aziendale, fino alla creazione di un tavolo aperto con il nostro team dedicato alla sostenibilità, per condividere obiettivi e strategie. Questo è il nostro impegno.

Quadrifoglio Group, etica consapevole.



The mark of responsible forestry  
Look for our FSC™-certified products

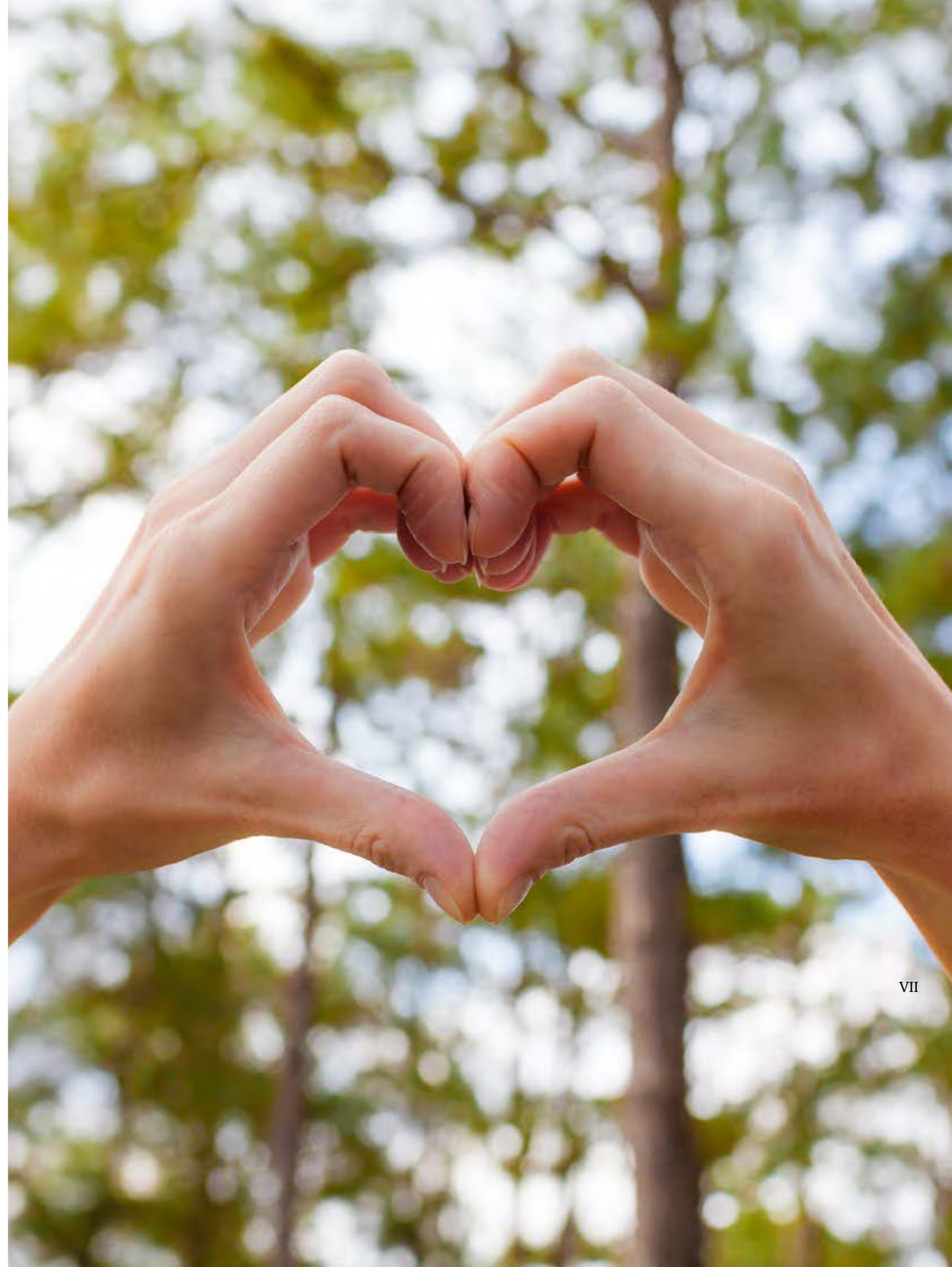

# Klavertje vier, Trèfle à quatre feuilles, Four-leaf clover, четырёхлистный клевер

## An international empathy

In all languages and cultures, Made in Italy is synonymous with quality raw materials, attention to detail and elegance. We export our exclusive and universally-recognised approach and method to Europe and the rest of the world.

At the Quadrifoglio Group Made in Italy means being in touch with the needs of the present: familiarity with different cultures, understanding people's needs and designing solutions tailored to future habits. We speak the language of the foreign markets through an international style and, thanks to our sales and marketing departments, we communicate with our customers in their own languages because making people feel part of a family is the absolute epitome of care and professionalism in our opinion.

Quadrifoglio Group, Italy. World.

# Klavertje vier, Trèfle à quatre feuilles, Four-leaf clover, четырёхлистный клевер

## Un'empatia internazionale

In tutte le lingue e le culture, Made in Italy è sinonimo di qualità delle materie prime, attenzione ai dettagli ed eleganza. Esportiamo in Europa e in tutto il mondo un modo di essere e di fare esclusivo, riconosciuto universalmente.

VIII

In Quadrifoglio Group Made in Italy significa essere in ascolto delle necessità del presente: conoscere diverse culture, comprendere le esigenze delle persone e disegnare soluzioni a misura delle abitudini che verranno. Parliamo il linguaggio dei mercati esteri attraverso uno stile internazionale e, grazie ai nostri dipartimenti, commerciale e marketing, comunichiamo con i clienti nelle loro lingue madri, perché far sentire le persone come in famiglia per noi è la massima espressione di cura e professionalità.

Quadrifoglio Group, Italia. Mondo.



## Decorative Lighting Index

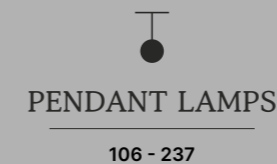
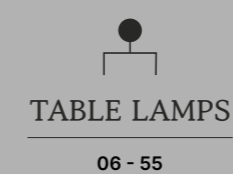

## Architectural Lighting Index



## Office Lighting Index



Lighting & Acoustic Collection

## Decorative Lighting

**Light emotions.  
Soft, sinuous or geometric  
lines: decorative lamps are  
available in different covers,  
materials, textures and colours.  
Every single detail is designed  
to create an appealing  
ambience in living, hospitality  
and business interiors.**

### Emozioni di luce.

Linee morbide, sinuose o geometriche: le lampade decorative sono disponibili in diversi rivestimenti, materiali, texture e colori. Ogni dettaglio è studiato per creare atmosfere suggestive in ambienti living, hospitality e business.

## Products Index

Decorative Lighting



### TABLE LAMPS

AFRA - 8  
BALANCE - 14  
CD LED - 20  
GRACE - 32  
HALF MOON - 38  
OLA - 44  
SUN - 50



### FLOOR LAMPS

AFRA - 58  
BABEL - 64  
CD LED - 70  
GRACE - 76  
HALF MOON - 82  
OLA - 88  
WARM - 100



### PENDANT LAMPS

ADD - 108  
AFRA - 114  
BABEL - 120  
BLONDE - 126  
CD LED - 132  
DRINK - 140  
ESCAPE - 146  
GOUT - 152  
GRACE - 158  
HALF MOON - 164  
MIRAGE - 170  
OLA - 176  
OLA FLY - 182  
PIPES - 188  
PLANET - 194  
SLICE - 202  
STARLIGHT - 208  
SUN - 214  
SVEVA - 220  
TUBE - 226  
TUBE MICRO - 232



### WALL/CEILING LAMPS

ALALUNGA - 240  
CD LED - 246  
DRINK - 252  
ESCAPE - 258  
OLA SLIM - 264  
SHADOW - 270  
SLICE - 276  
STARLIGHT - 282  
TUBE - 288  
TUPLA - 296  
TURN ME! - 302

### SYMBOL LEGEND

LEGENDA SIMBOLI

400

# Family Index

Decorative Lighting



ADD

ADD PENDANT - 108

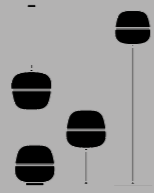

AFRA

AFRA TABLE - 8  
AFRA FLOOR - 58  
AFRA PENDANT - 114



ALALUNGA

ALALUNGA WALL - 240



BABEL

BABEL FLOOR - 64  
BABEL PENDANT - 120

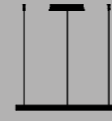

PLANET

PLANET PENDANT - 194



SHADOW

SHADOW WALL - 270



SLICE

SLICE PENDANT - 202  
SLICE WALL/CEILING - 276

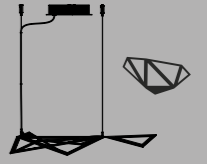

STARLIGHT

STARLIGHT PENDANT - 208  
STARLIGHT WALL - 282

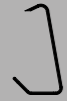

BALANCE

BALANCE TABLE - 14



BLONDE

BLONDE PENDANT - 126

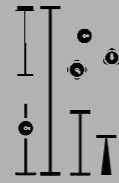

CD LED

CD LED TABLE - 20  
CD LED FLOOR - 70  
CD LED PENDANT - 132  
CD LED WALL - 246



DRINK

DRINK PENDANT - 140  
DRINK CEILING - 252



SUN

SUN TABLE - 50  
SUN PENDANT - 214

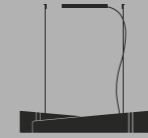

SVEVA

SVEVA PENDANT - 220



TUBE

TUBE PENDANT - 226  
TUBE WALL/CEILING - 288



TUBE MICRO

TUBE MICRO PENDANT - 232

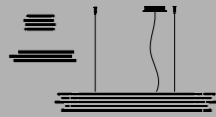

ESCAPE

ESCAPE PENDANT - 146  
ESCAPE WALL - 258



GOUT

GOUT PENDANT - 152

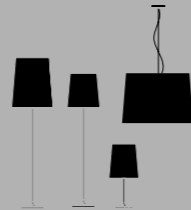

GRACE

GRACE TABLE - 32  
GRACE FLOOR - 76  
GRACE PENDANT - 158

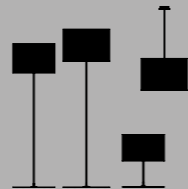

HALF MOON

HALF MOON TABLE - 38  
HALF MOON FLOOR - 82  
HALF MOON PENDANT - 164



TUPLA

TUPLA WALL - 296



TURN ME!

TURN ME! WALL - 302



WARM

WARM FLOOR - 100



MIRAGE

MIRAGE PENDANT - 170

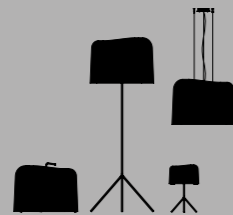

OLA

OLA TABLE - 44  
OLA FLOOR - 88  
OLA PENDANT - 176



OLA SLIM

OLA FLY PENDANT - 182  
OLA SLIM WALL/CEILING - 264



PIPES

PIPES PENDANT - 188

# Family Index

Decorative Lighting

# Table Lamps

Decorative Lighting



## Table lamps

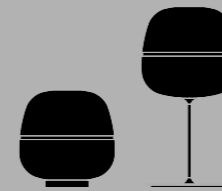

AFRA

AFRA TABLE - 8



BALANCE

BALANCE TABLE - 14

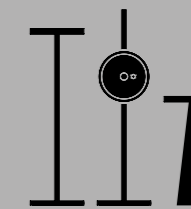

CD LED

CD LED TABLE - 20



GRACE

GRACE TABLE - 32



HALF MOON

HALF MOON TABLE - 38



OLA

OLA TABLE - 44



SUN

SUN TABLE - 50



designed by Enrico Franzolini

**Opal transparency.  
Opaline glass and painted  
aluminium converge in the full-  
bodied shape of Afra, available  
in the version with pedestal  
and support base. The light is  
diffused and dimmable, ideal for  
bedside cabinets, cupboards  
and receptions.**

Trasparenze d'opale.

Vetro opalino e alluminio verniciato si incontrano nella forma piena di Afra, disponibile nelle versioni con piedistallo e base d'appoggio. La luce è diffusa e dimmerabile, ideale per comodini, madie, consolle e reception.



TABLE LAMPS



AFRA table lamp | Matt White acid-etched glass shade and Matt White base  
BLOOM credenza | American Walnut doors and sides, Invisible White porcelain stoneware top and Umbra Grey legs

Lighting & Acoustic Collection





## Table lamp

AFRA

Table lamp with white acid etched blown glass shade and powder coated metal frame.  
Lampada da tavolo con paralume in vetro soffiato acidato bianco e base in metallo verniciato.

MAX 1XE27 100W  
220-240V  
ON-OFF | Dimmer

CE IP20

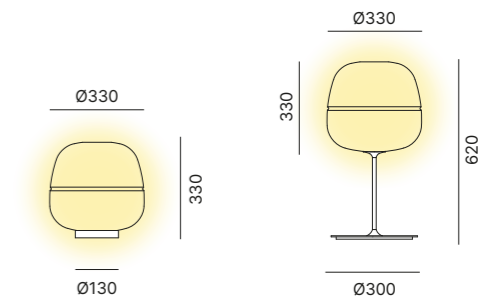

For the icon summary refer to pages 400 - 403 / Per la legenda icone vedere pp. 400 - 403

### SHADE FINISH OPTIONS FINITURE PARALUME

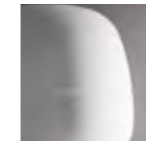

White acid-etched glass

### CAP (optional) CUFFIA (opzionale)

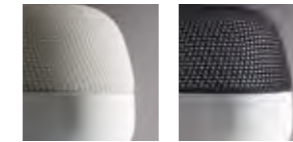

Beige

Black

### FRAME FINISH OPTIONS FINITURE STRUTTURA



Matt White



Black Goffratino

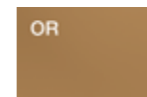

Gold



Bronze



Corten

## Afra collection

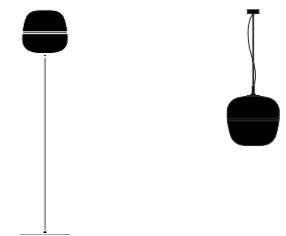

AFRA FLOOR  
58

AFRA PENDANT  
114

# BALANCE

designed by Thomas Feichtner

**Dynamic balance.**  
Balance arises from an essential design: tubular curved aluminium defines a minimal and slender structure that can be positioned horizontally or vertically, to direct light on the table in the office or in the home office.

Equilibrio dinamico.

Balance è frutto di un disegno essenziale: l'alluminio tubolare curvato tratteggia una struttura minimal e sottile, orientabile in orizzontale e in verticale per direzionare la luce sul tavolo in ufficio o nell'home office.



TABLE LAMPS



BALANCE table lamp | Matt White  
X9 executive desk | Elm top and Matt White legs  
DIVA SOFT executive chair | C05/280 fabric and Chrome frame

Lighting & Acoustic Collection

DESIGN LIGHTING





## Table lamp

## BALANCE

Table lamp in white or black painted aluminium.  
Lampada da tavolo in alluminio verniciato bianco o nero.

4,8W LED  
110-240V  
2700 K  
CRI80  
ON-OFF

CE IP20   120lm UGR<sub>19</sub>

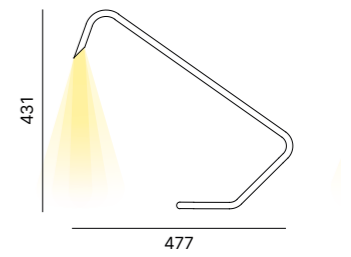
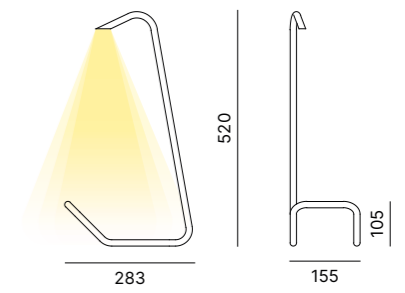

For the icon summary refer to pages 400 - 403 / Per la legenda icone vedere pp. 400 - 403

### LAMP FINISH OPTIONS FINITURE LAMPADA



Matt White    Black Goffratino



designed by Moreno De Giorgio

**Geometries of style.  
An minimalistic lamp, with  
a sophisticated soul and an  
assemblable structure.  
CD Led can be customised in  
terms of shape and colour, to  
adapt it to tables in different  
settings, including residential  
and hospitality use.**

Geometrie di stile.

Una lampada minimale, con un'anima sofisticata e una struttura multiforme: CD Led si può personalizzare nelle forme e nei colori per adattarla ai tavoli di diversi contesti, residenziali e ricettivi.



TABLE LAMPS





The CD Led base is available in a conical or circular version and the structure can be completed with a geometric element, available in a circular, square or triangular shape and customisable in numerous colours.

Il basamento di CD Led è disponibile in versione conica o circolare e la struttura si può completare con un elemento geometrico a scelta tra cerchio, quadrato e triangolo, customizzabile in numerosi colori.

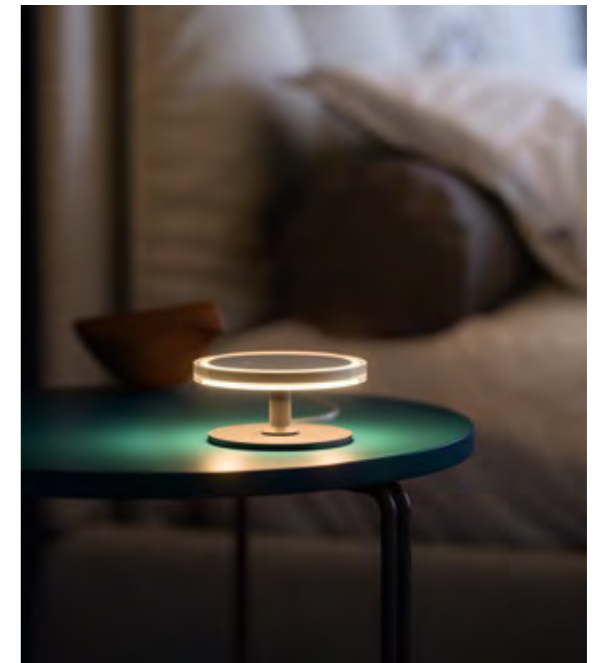

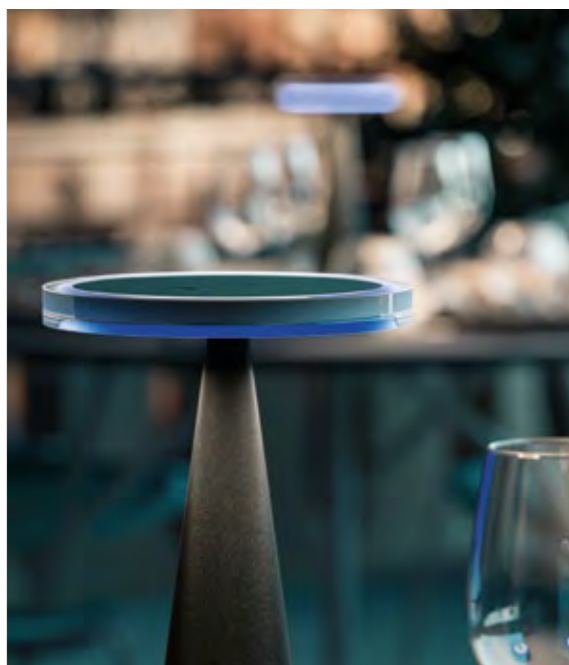

**The powerful led light is adjustable with a mechanical dimmer, ideal for lighting reception areas, coffee tables, living room tables and bedside cabinets with personality.**

La luce a led è potente e regolabile tramite un meccanismo dimmer, ideale per illuminare con personalità reception, tavolini, tavoli della zona giorno e comodini dell'area notte.





Table lamp

CD LED

Polycarbonate lamp diffuser with transparent or colored PMMA ring, powder coated metal frame.  
 Diffusore in policarbonato con anello in PMMA trasparente o colorato, struttura in metallo verniciato.

9,5W LED  
 110-240V  
 2700K  
 CRI90  
 Gesture dimm

CE IP20 LED 24V 1250lm MacAdam Step 3  
 UGR<sub>19</sub>

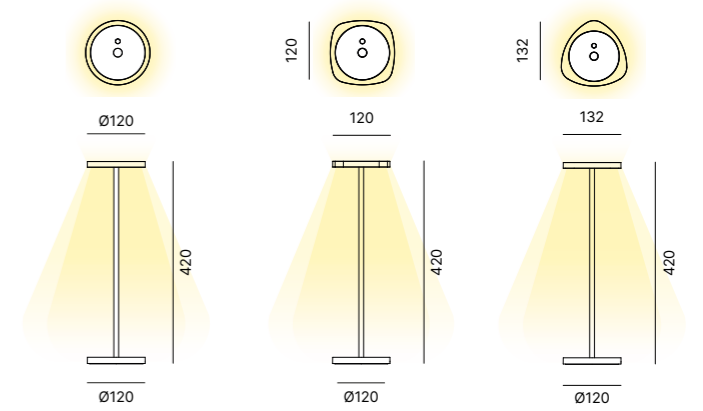

For the icon summary refer to pages 400 - 403 / Per la legenda icone vedere pp. 400 - 403

FINISH OPTIONS  
 FINITURE

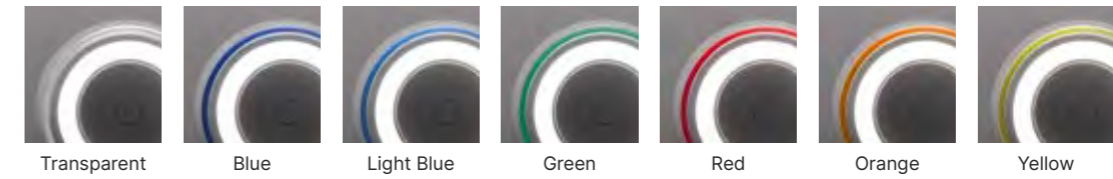

FRAME FINISH OPTIONS  
 FINITURE STRUTTURA



Matt Black

CD Led collection

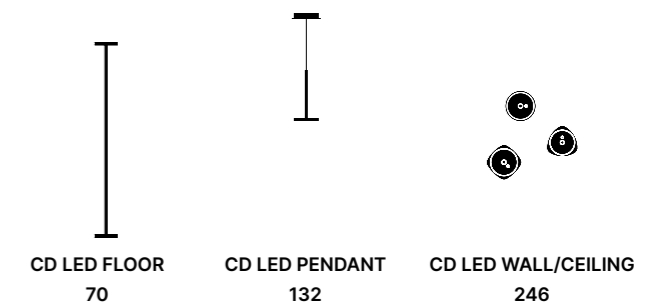



Table lamp

CD LED

Polycarbonate lamp diffuser with transparent or colored PMMA ring, powder coated metal frame.  
 Diffusore in policarbonato con anello in PMMA trasparente o colorato, struttura in metallo verniciato.

9,5W LED  
 110-240V  
 2700K  
 CRI90  
 Gesture dimm

CE IP20 LED 24V 1250lm MacAdam Step 3  
 UGR<sub>19</sub>

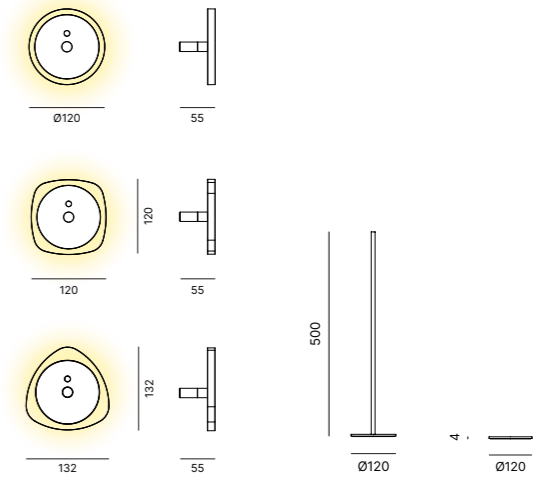

For the icon summary refer to pages 400 - 403 / Per la legenda icone vedere pp. 400 - 403

FINISH OPTIONS  
 FINITURE

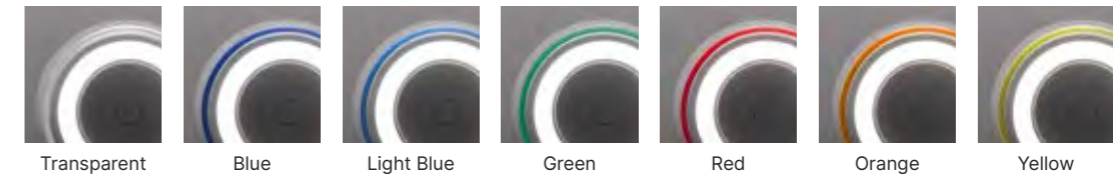

FRAME FINISH OPTIONS  
 FINITURE STRUTTURA



Matt Black

CD Led collection

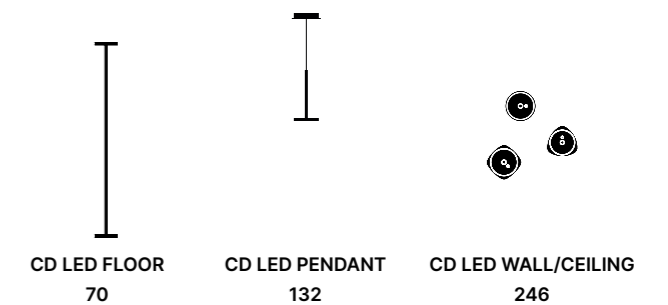

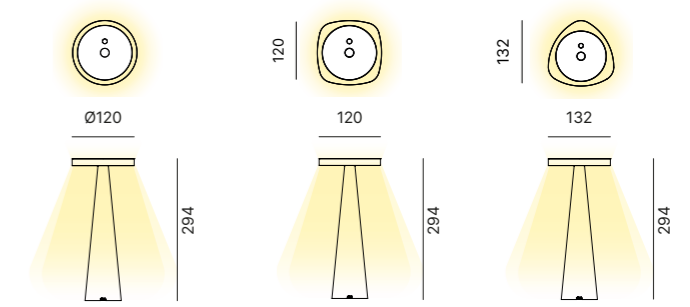

Table lamp

CD LED

Polycarbonate lamp diffuser with transparent or colored PMMA ring, powder coated metal frame.  
 Diffusore in policarbonato con anello in PMMA trasparente o colorato, struttura in metallo verniciato.

3W LED  
 110-240V  
 2700K  
 CRI90  
 Touch dimm



CE IP20 [Square Icon] [LED Icon] [MacAdam Step 3 Icon]

For the icon summary refer to pages 400 - 403 / Per la legenda icone vedere pp. 400 - 403

FINISH OPTIONS  
 FINITURE

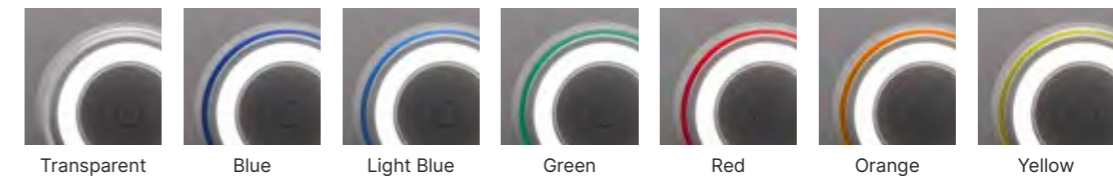

FRAME FINISH OPTIONS  
 FINITURE STRUTTURA



Matt Black

CD Led collection

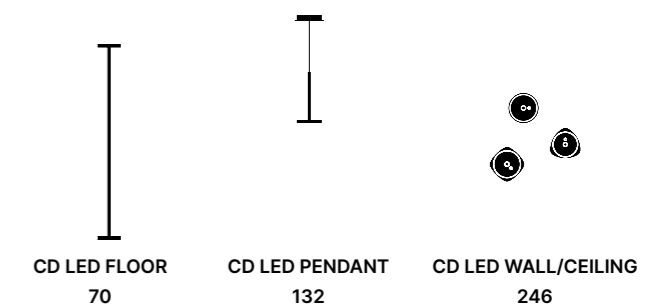



designed by Moreno De Giorgio

**Renewed imagination.  
Grace reinterprets the traditional  
shape of the lamp through  
original finishings, from the  
round and perforated base to the  
shade fabric: a highly suitable  
solution for residential interiors  
and executive business settings  
alike.**

Immaginario rinnovato.  
Grace reinterpreta la forma tradizionale della lampada attraverso  
finiture inedite, dal basamento circolare forato, fino al tessuto  
del paralume: una soluzione che ben si presta sia per ambienti  
residenziali sia per spazi di business direzionali.

  
TABLE LAMPS



GRACE table lamp | Black Goffratino frame and Black Cotton shade  
X5 desk | Umbra Grey legs and Eucalyptus top  
CITY design chair | E04/488 fabric and Gold frame  
P1 Boiserie | Eucalyptus panels and shelves





## Table lamp

Table lamp with powder coated metal frame, linen or cotton shade.

Lampada da tavolo con stelo in metallo verniciato, paralume in lino o cotone.

MAX 1XE27 100W  
220-240V  
ON-OFF | Dimmer

CE IP20 

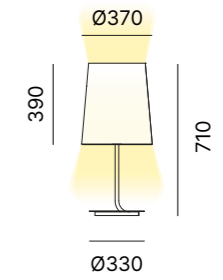

For the icon summary refer to pages 400 - 403 / Per la legenda icone vedere pp. 400 - 403

### SHADE FINISH OPTIONS FINITURE PARALUME

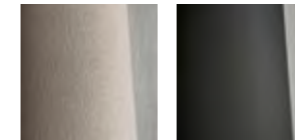

Natural Linen    Black Cotton

### FRAME FINISH OPTIONS FINITURE STRUTTURA



Black Goffratino    Gold    Bronze    Corten

## Grace collection

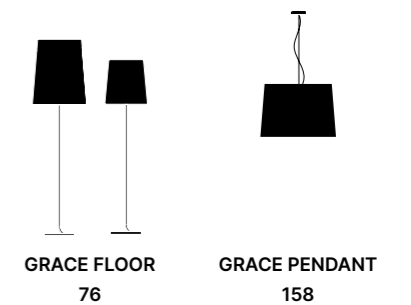

GRACE FLOOR  
76

GRACE PENDANT  
158

# HALF MOON

designed by Enrico Franzolini & Vicente García Jimenez

**Concrete style.  
Classical shapes and multi-  
faceted nature: Half Moon is the  
right table lamp for enhancing  
residential, business and  
hospitality settings.  
The stem can be customised  
in the colours black goffratino,  
bronze, gold and corten, for a  
precious touch.**

38

Stile concreto.

Forme classiche e natura poliedrica: Half Moon è la lampada da tavolo giusta per valorizzare spazi residenziali, business e hospitality. Lo stelo è personalizzabile nei colori nero goffratino, bronzo, oro e corten, per un tocco prezioso.



TABLE LAMPS



39



**The shade of Half Moon is made of linen or cotton and can be fitted with a neutral or coloured inner cover. Available tonalities combine with the light when on, warming the ambience of interiors.**

Il paralume di Half Moon è in lino o in cotone e si può dotare all'interno di un rivestimento coprente, neutro o colorato. Le tonalità a disposizione, abbinata alla luce accesa, scaldano l'atmosfera degli ambienti.



## Table lamp

## HALF MOON

Table lamp with powder coated metal frame, linen or cotton shade with white or colored inside.

Lampada da tavolo con stelo in metallo verniciato, paralume in lino o cotone con interno coprente bianco o colorato.

MAX 1XE27 100W  
220-240V  
ON-OFF | Dimmer

CE IP20 

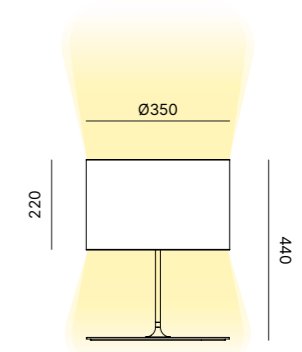

For the icon summary refer to pages 400 - 403 / Per la legenda icone vedere pp. 400 - 403

### SHADE FINISH OPTIONS FINITURE PARALUME



Black Cotton White inside    Black Cotton Yellow inside    Black Cotton Orange inside    Black Cotton Fuchsia inside    Natural Linen White inside    Natural Linen Yellow inside    Natural Linen Orange inside    Natural Linen Fuchsia inside

### FRAME FINISH OPTIONS FINITURE STRUTTURA

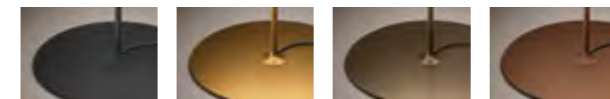

Black Goffratino    Gold    Bronze    Corten

## Half Moon collection

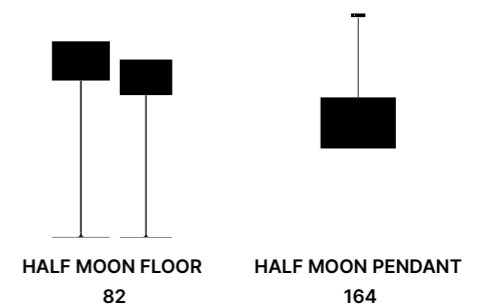



designed by Enrico Franzolini

**Technology and material.  
Designed for hospitality  
and residential interiors, Ola  
combines formal research  
and material, culminating  
in an iconic lamp featuring  
a painted metal stem and  
fibreglass shade.**

**Tecnologia e materia.**

Progettata per ambiti hospitality e residenziali, Ola è la sintesi di una ricerca formale e materiale: nasce così questa lampada iconica, con stelo in metallo verniciato e paralume in fibra di vetro.



TABLE LAMPS





OLA table lamp | Black Goffratino frame and White fibreglass shade  
BLOOM credenza | Noir Desir porcelain stoneware doors, Umbra Grey lacquered top and sides, Bronze Flair legs





## Table lamp

Table lamp with fibreglass shade and black powder coated metal frame.  
Lampada da tavolo con paralume in fibra di vetro, stelo in metallo verniciato nero.

MAX 1XE27 100W  
220-240V  
ON-OFF | Dimmer

CE IP20 

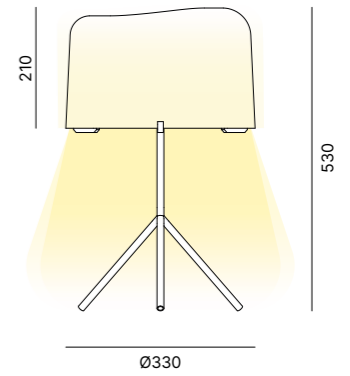

For the icon summary refer to pages 400 - 403 / Per la legenda icone vedere pp. 400 - 403

### SHADE FINISH OPTIONS FINITURE PARALUME

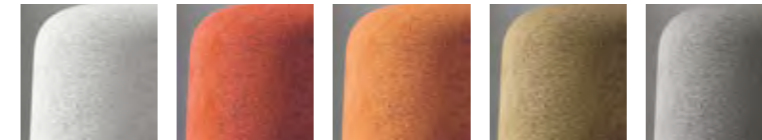

White fibreglass   Red fibreglass   Orange fibreglass   Gold fibreglass   Silver fibreglass

### FRAME FINISH OPTIONS FINITURE STRUTTURA



Black Goffratino

## Ola collection

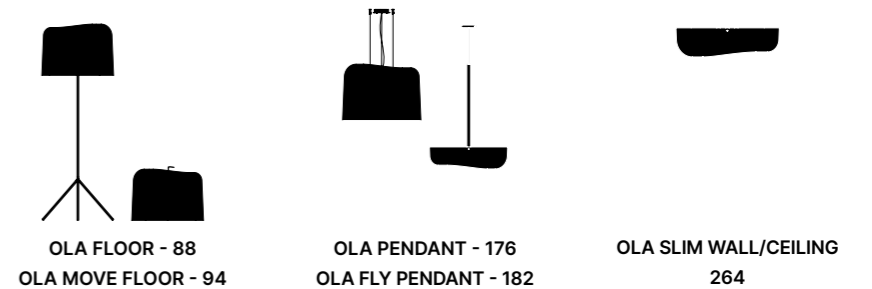

OLA FLOOR - 88  
OLA MOVE FLOOR - 94

OLA PENDANT - 176  
OLA FLY PENDANT - 182

OLA SLIM WALL/CEILING  
264

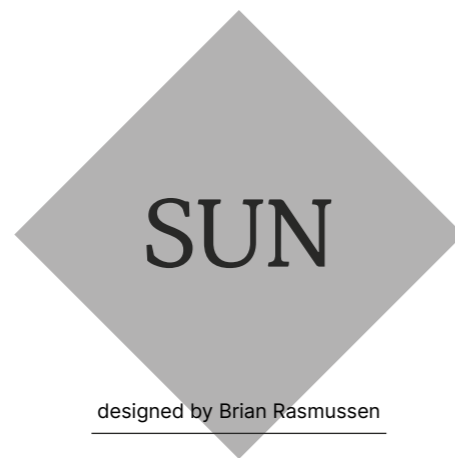

**Broken down light.  
Ideal for original and  
creative settings, Sun  
consists of a metal base  
and a shade available in 3  
tonalities, which fragments  
and reflects light, with no  
less than 96 fabric parts.**

**Luce scomposta.**  
Ideale per ambienti ricercati e creativi, Sun è formata da una base in metallo e un paralume, disponibile in 3 tonalità, che frammenta e riflette la luce, grazie alla lavorazione di 96 parti di tessuto.



TABLE LAMPS



SUN table lamp | Matt White frame and White fabric shade  
BLOOM credenza | American Walnut doors, sides and top, Bronze legs





### Table lamp

### SUN

Table lamp with fabric shade and matt white powder coated metal frame.

Lampada da tavolo con paralume in tessuto e stelo in metallo verniciato bianco opaco.

MAX 1XE27 100W  
220-240V  
ON-OFF | Dimmer

CE IP20

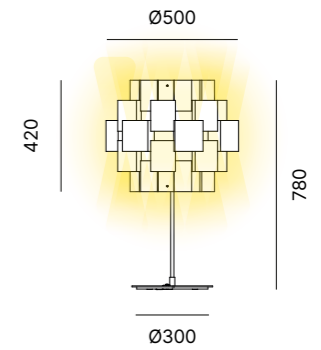

For the icon summary refer to pages 400 - 403 / Per la legenda icone vedere pp. 400 - 403

#### SHADE FINISH OPTIONS FINITURE PARALUME



White fabric    Black fabric    Red fabric

#### FRAME FINISH OPTIONS FINITURE STRUTTURA



Matt White

### Sun collection

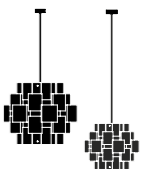

SUN PENDANT  
214

# Floor Lamps

Decorative Lighting



## Floor lamps



AFRA

AFRA FLOOR - 58



BABEL

BABEL FLOOR - 64

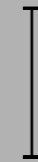

CD LED

CD LED FLOOR - 70



GRACE

GRACE FLOOR - 76



HALF MOON

HALF MOON FLOOR - 82

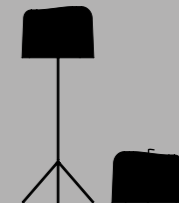

OLA

OLA FLOOR - 88  
OLA MOVE FLOOR - 94



WARM

WARM FLOOR - 100



**A globe of light.  
The aluminium structure  
culminates in a bubble  
of opaline glass light,  
customisable with a  
handmade fabric cover:  
Afra is the perfect lamp for  
refined and shared settings.**

**Globo di luce.  
La struttura in alluminio culmina in una bolla di  
luce in vetro opalino, personalizzabile con una  
cuffia in tessuto fatta a mano: Afra è la lampada  
perfetta per ambienti raffinati e condivisi.**





AFRA floor lamp | Matt White acid-etched glass shade and Matt White frame  
CLEOPAS armchair and ottoman | D04/397 fabric and Umbra Grey base  
ALTER EGO mirrors



## Floor lamp

AFRA

Floor lamp with white acid etched blown glass shade and powder coated metal frame.

Lampada da terra con paralume in vetro soffiato acidato bianco e base in metallo verniciato.

MAX 1XE27 100W  
220-240V  
ON-OFF | Dimmer

CE IP20 

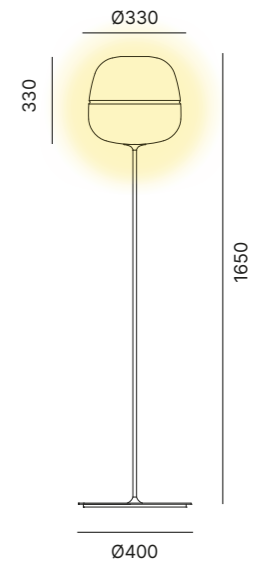

For the icon summary refer to pages 400 - 403 / Per la legenda icone vedere pp. 400 - 403

### SHADE FINISH OPTIONS FINITURE PARALUME

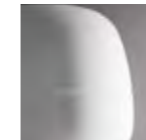

White acid-etched glass

### CAP (optional) CUFFIA (opzionale)



Beige

Black

### FRAME FINISH OPTIONS FINITURE STRUTTURA



Matt White



Black Goffratino

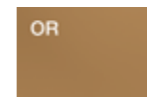

Gold



Bronze



Corten

## Afra collection

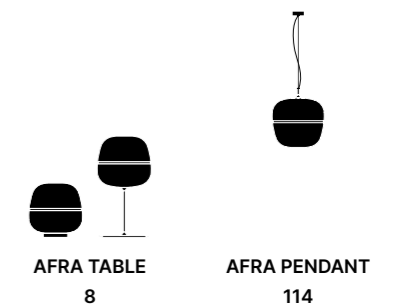

AFRA TABLE  
8

AFRA PENDANT  
114



**Ancient genesis.  
The shade is inspired by  
the legendary unfinished  
tower of Babel and replicates  
its ascending shape in the  
fabric shade, supported by  
a metal tripod: a suitable  
design for public and private  
settings alike.**

Genesi antica.

La lampada si ispira alla mitica torre incompiuta di Babele e ne replica la forma ascendente nel paralume in tessuto, poggiato su un treppiede in metallo: un design adatto per spazi pubblici e privati.



FLOOR LAMPS



BABEL floor lamp | Black fabric shade and Black Goffratino frame  
MONTREAL side table | Fokos Piombo porcelain stoneware top and Umbra Grey frame





## Floor lamp

# BABEL

Floor lamp with honeycomb fabric shade and powder coated metal frame.  
Paralume in tessuto a nido d'ape, base in metallo verniciato.

MAX 3XE27 60W  
220-240V  
ON-OFF | Dimmer

CE  IP20

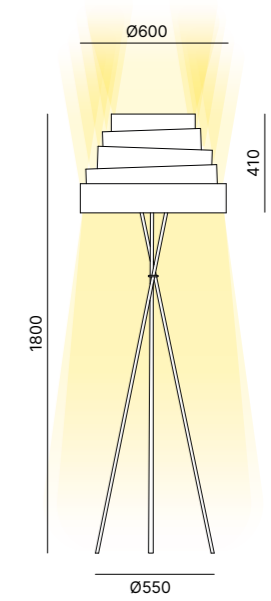

For the icon summary refer to pages 400 - 403 / Per la legenda icone vedere pp. 400 - 403

### SHADE FINISH OPTIONS FINITURE PARALUME



White

Black

### FRAME FINISH OPTIONS FINITURE STRUTTURA



Matt White

Black Goffratino

Gold

Bronze

Corten

## Babel collection



BABEL PENDANT  
120



designed by Moreno De Giorgio

**Flexible identity.  
Ideal as a reading lamp or  
as an ambience-setting  
light point for domestic and  
hospitality interiors, CD Led  
features an minimalistic and  
customisable design that  
characterises all settings  
with a tailored style.**

**Identità flessibile.  
Ideale come lampada da lettura o come punto luce  
d'atmosfera per spazi domestici e ricettivi,  
CD Led ha un design minimal e personalizzabile, per  
caratterizzare ogni ambiente con uno stile su misura.**



FLOOR LAMPS



CD LED floor lamps | Matt Black  
ARTE sofa | M01/554 fabric

Lighting & Acoustic Collection





Floor lamp

CD LED

Polycarbonate lamp diffuser with transparent or colored PMMA ring, powder coated metal frame.  
 Diffusore in policarbonato con anello in PMMA trasparente o colorato, struttura in metallo verniciato.

9,5W LED  
 110-240V  
 2700K  
 CRI90  
 Gesture dimm

CE IP20 LED 24V 1250lm MacAdam Step 3  
 UGR<sub>19</sub>

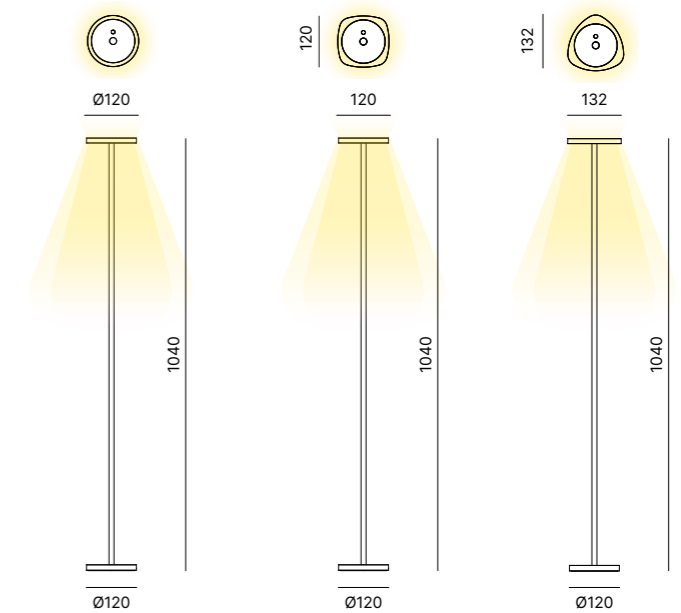

For the icon summary refer to pages 400 - 403 / Per la legenda icone vedere pp. 400 - 403

FINISH OPTIONS  
 FINITURE

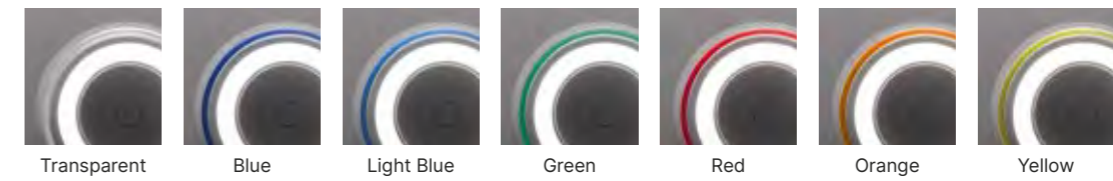

FRAME FINISH OPTIONS  
 FINITURE STRUTTURA



Matt Black

CD Led collection

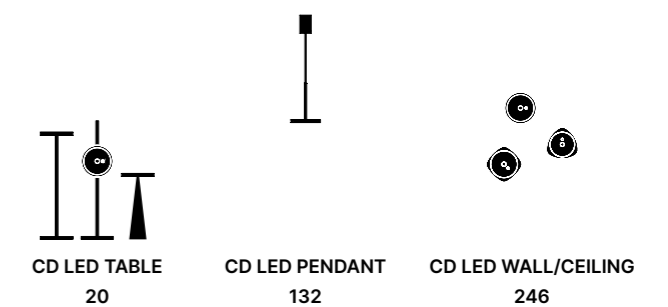



designed by Moreno De Giorgio

**Natural aesthetics.  
Grace exquisitely adapts to  
different settings, thanks  
to its two versions, small  
and big. Its classical shapes  
are exalted by original  
finishings, like the natural  
linen or black cotton shade.**

**Estetica naturale.**

Grace si adatta con garbo a diversi ambienti, grazie alle due versioni, piccola e grande, e alle forme classiche esaltate da finiture ricercate, come il paralume in lino naturale o cotone nero.



FLOOR LAMPS



GRACE floor lamps | Natural Linen shade and Black Goffratino frame  
MELBOURNE pouf | E03/464 fabric and Oak varnished solid ash wood legs  
MELBOURNE side table | Fokos Terra porcelain stoneware top and Oak varnished solid ash wood legs  
CITY DÉCO LOUNGE armchair | E04/476 fabric and Bronze frame



## Floor lamp

GRACE

Floor lamp with powder coated metal frame, linen or cotton shade.

Lampada da terra con stelo in metallo verniciato, paralume in lino o cotone.

### Grace small

MAX 1XE27 100W  
220-240V  
ON-OFF | Dimmer

### Grace

MAX 3XE27 60W  
220-240V  
ON-OFF | Dimmer

CE IP20 

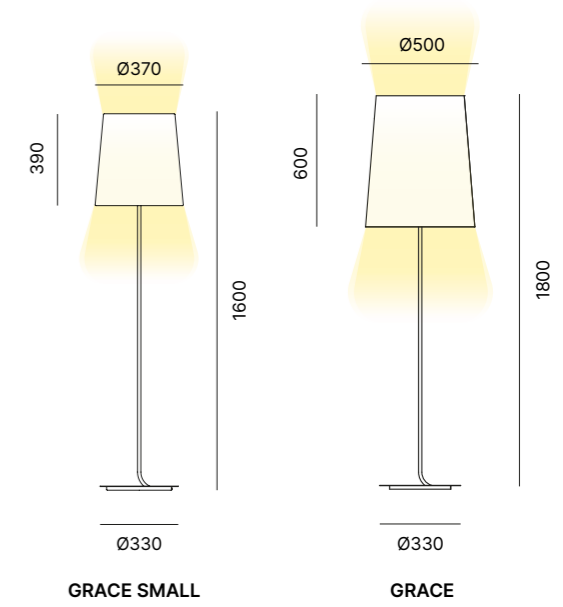

For the icon summary refer to pages 400 - 403 / Per la legenda icone vedere pp. 400 - 403

### SHADE FINISH OPTIONS FINITURE PARALUME

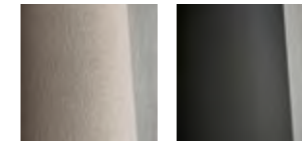

Natural Linen    Black Cotton

### FRAME FINISH OPTIONS FINITURE STRUTTURA



Black Goffratino    Gold    Bronze    Corten

## Grace collection

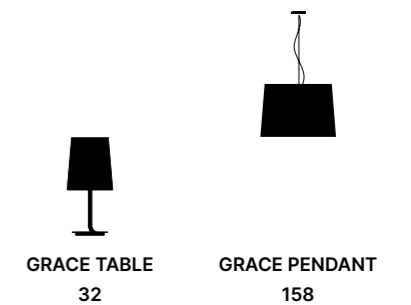

# HALF MOON

designed by Enrico Franzolini & Vicente García Jimenez

**Timelessly classic.  
Half Moon is the perfect  
lamp for all shared spaces:  
it is ideal next to armchairs,  
sofas and ottomans and can  
be customised with different  
colour options. It is available in a  
big or small version, to enhance  
interiors of different sizes.**

Classico attuale.

Half Moon è la lampada perfetta per qualsiasi spazio di condivisione: ideale accanto a poltrone, divani e pouf, è personalizzabile nei colori e disponibile in versione grande o piccola, per valorizzare ambienti di diversa metratura.



FLOOR LAMPS



HALF MOON floor lamp | Black Goffratino frame and Black Cotton shade  
ARCO armchair | Walnut varnished solid ash wood arms and D02/268 fabric  
MONTREAL side table | Invisible White porcelain stoneware top and Umbra Gray frame



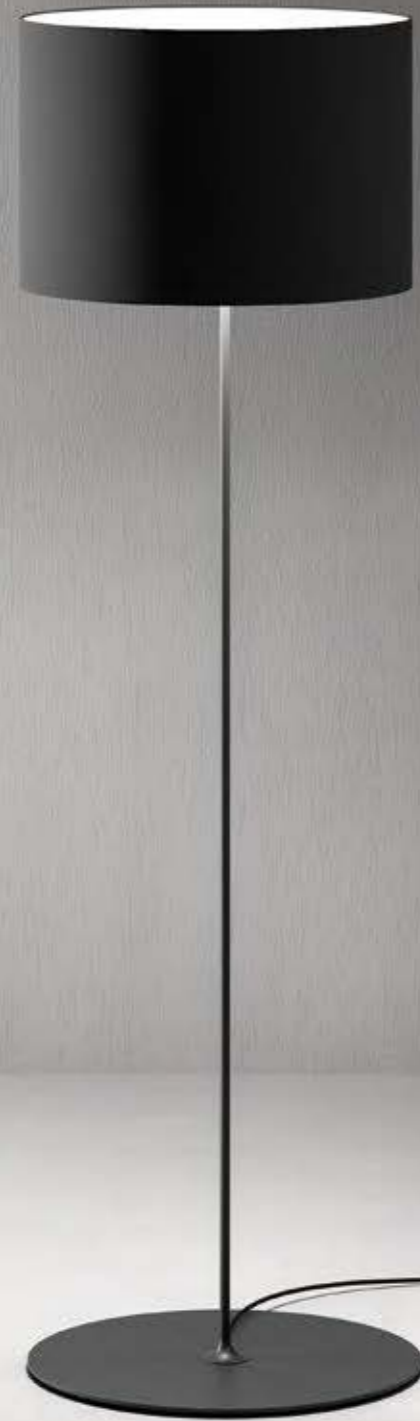

Floor lamp

HALF MOON

Floor lamp with powder coated metal frame, linen or cotton shade with white or colored inside.  
Lampada da terra con stelo in metallo verniciato, paralume in lino o cotone con interno coprente bianco o colorato.

**Half Moon small**  
MAX 1XE27 100W  
220-240V  
ON-OFF | Dimmer

**Half Moon**  
MAX 3XE27 60W  
220-240V  
ON-OFF | Dimmer

CE IP20

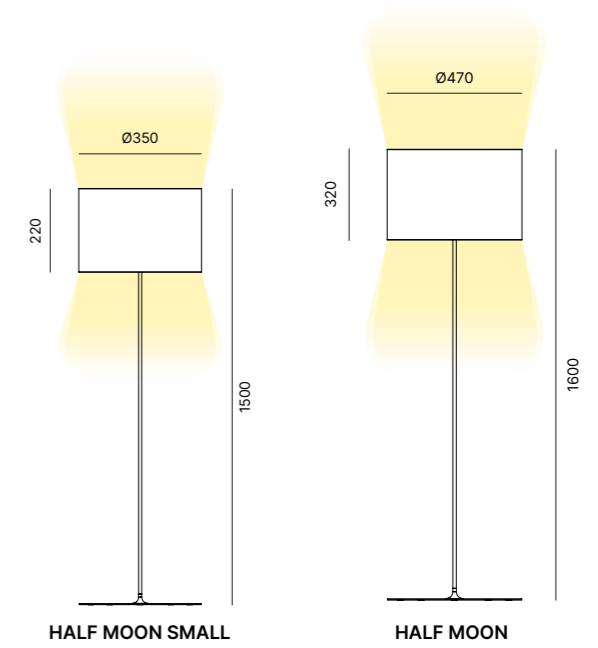

For the icon summary refer to pages 400 - 403 / Per la legenda icone vedere pp. 400 - 403

SHADE FINISH OPTIONS  
FINITURE PARALUME



FRAME FINISH OPTIONS  
FINITURE STRUTTURA



Half Moon collection

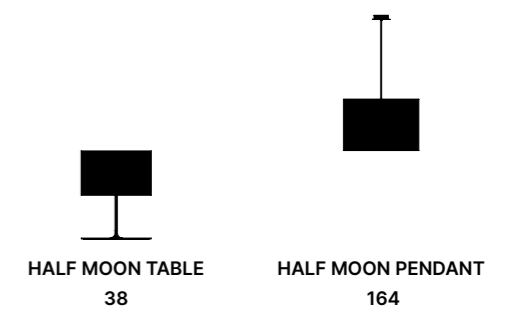



**Materialised sensation.  
Original materials and  
unprecedented shapes  
interpret a new concept  
of lighting. Ola is the floor  
lamp that turns light into  
ambience, thanks to the  
fibreglass shade available  
in five colours.**

Sensazione materializzata.  
Materiali inediti e forme originali interpretano un nuovo concetto di  
illuminazione: Ola è la lampada da terra capace di trasformare la luce in  
atmosfera, grazie a cinque colorazioni del paralume in fibra di vetro.





OLA floor lamp | Black Goffratino frame and White fibreglass shade  
AGIO armchair | E04/475 fabric and Chrome frame  
ARTE sofa | D04/384 fabric and Chrome legs  
MONTREAL metal pot | Bronze



## Floor lamp

## OLA

Floor lamp with fibreglass shade and black powder coated metal frame.

Lampada da terra con paralume in fibra di vetro, stelo in metallo verniciato nero.

MAX 3XE27 60W  
220-240V  
ON-OFF | Dimmer

CE IP20 

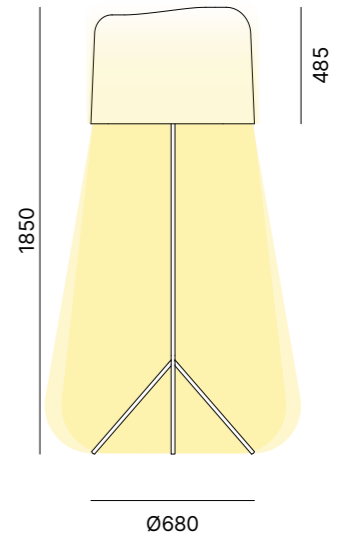

For the icon summary refer to pages 400 - 403 / Per la legenda icone vedere pp. 400 - 403

### SHADE FINISH OPTIONS FINITURE PARALUME



White fibreglass

Red fibreglass

Orange fibreglass

Gold fibreglass

Silver fibreglass

### FRAME FINISH OPTIONS FINITURE STRUTTURA



Black Goffratino

## Ola collection



OLA TABLE  
44



OLA MOVE FLOOR  
94

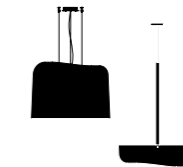

OLA PENDANT - 176  
OLA FLY PENDANT - 182



OLA SLIM WALL/CEILING  
264

# OLA MOVE

designed by Enrico Franzolini

**Stylish movement.  
Warm, inviting and diffused  
lighting. Ola Move is the floor  
lamp available in five colours,  
for furnishing professional  
and residential interiors. It can  
be moved anywhere thanks to  
the practical metal handle.**

**Movimento di stile.**

**Illuminazione calda, accogliente e diffusa: Ola Move è la lampada da terra disponibile in cinque colori per arredare ambienti professionali e residenziali. Si trasporta ovunque grazie alla pratica maniglia in metallo.**



FLOOR LAMPS

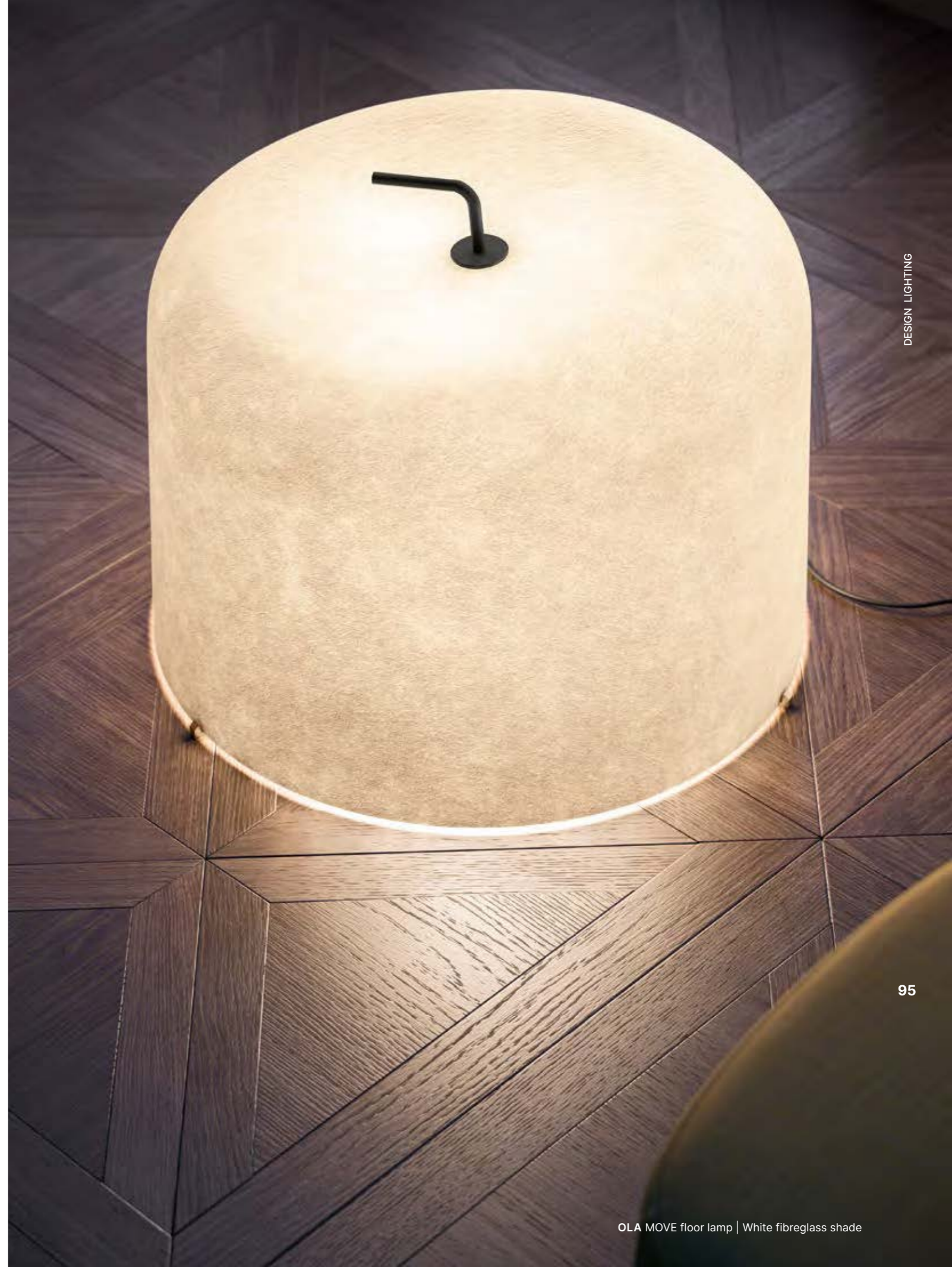

OLA MOVE floor lamp | White fibreglass shade  
CITY LOUNGE armchair | D05/413 fabric and Oak varnished solid ash wood legs  
MELBOURNE side table | Fokos Terra porcelain stoneware top and Oak varnished solid ash wood legs

Lighting & Acoustic Collection

DESIGN LIGHTING





## Floor lamp

## OLA MOVE

Floor lamp with fibreglass shade and black powder coated metal handle.

Lampada da terra con paralume in fibra di vetro, maniglia in metallo verniciato nero.

MAX 3XE27 60W  
220-240V  
ON-OFF | Dimmer

CE IP20

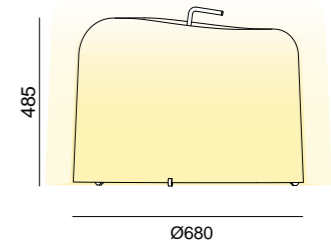

For the icon summary refer to pages 400 - 403 / Per la legenda icone vedere pp. 400 - 403

### SHADE FINISH OPTIONS FINITURE PARALUME

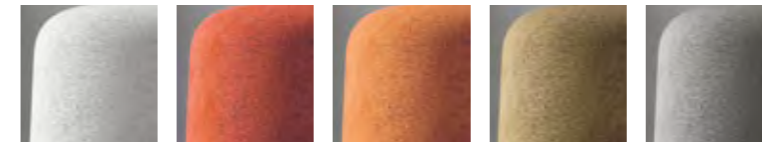

White fibreglass

Red fibreglass

Orange fibreglass

Gold fibreglass

Silver fibreglass

### FRAME FINISH OPTIONS FINITURE STRUTTURA



Black Goffratino

## Ola collection



OLA TABLE  
44

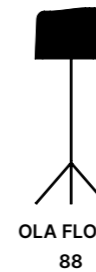

OLA FLOOR  
88

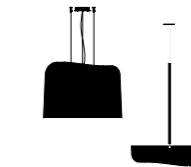

OLA PENDANT - 176  
OLA FLY PENDANT - 182



OLA SLIM WALL/CEILING  
264



**Enlightened mood.  
Available in an indoor and  
outdoor version, with decorative  
fabric mesh upon request, Warm  
characterises settings with  
its soft and undulating profile,  
providing lighting thanks to an  
internal diffuser.**

**Mood luminoso.  
Disponibile in versione indoor e outdoor, con rete  
decorativa in tessuto su richiesta, Warm caratterizza gli  
spazi con il suo profilo morbido e ondulato e li illumina  
grazie a un diffusore interno.**

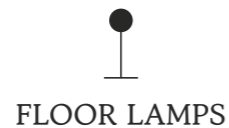

WARM floor lamp | White polyethylene shade and Black Goffratino frame  
COVE outdoor chair | White frame and D06/507 simil leather upholstered seat  
COZY coffee table | White frame and top





## Floor lamp

# WARM

Floor lamp with white polyethylene shade and zinc-plated steel base. Indoor and outdoor version available.  
Lampada da terra con diffusore in polietilene bianco e base in metallo zincato. Disponibile in versione indoor e outdoor.

MAX 1XE27 100W  
220-240V  
ON-OFF | Dimmer

CE IP20 IP68 

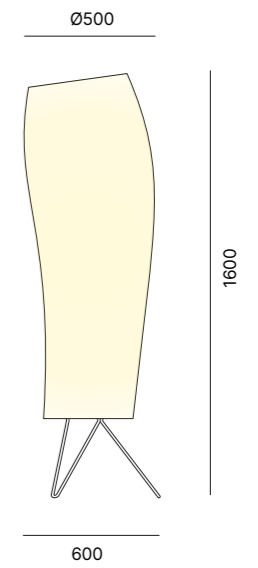

For the icon summary refer to pages 400 - 403 / Per la legenda icone vedere pp. 400 - 403

### SHADE FINISH OPTIONS FINITURE PARALUME



White  
polyethylene

### MESH (optional) RETE (opzionale)

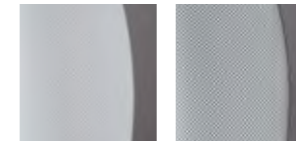

White

Black

### FRAME FINISH OPTIONS FINITURE STRUTTURA



Black Goffratino

# Pendant Lamps

Decorative Lighting



## Pendant lamps



ADD

ADD PENDANT - 108



AFRA

AFRA PENDANT - 114



BABEL

BABEL PENDANT - 120



BLONDE

BLONDE PENDANT - 126



CD LED

CD LED PENDANT - 132



DRINK

DRINK PENDANT - 140

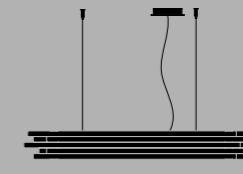

ESCAPE

ESCAPE PENDANT - 146



GOUT

GOUT PENDANT - 152



GRACE

GRACE PENDANT - 158



HALF MOON

HALF MOON PENDANT - 164



MIRAGE

MIRAGE PENDANT - 170

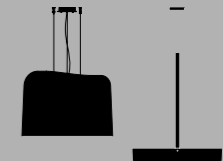

OLA

OLA PENDANT - 176  
OLA FLY PENDANT - 182



PIPES

PIPES PENDANT - 188

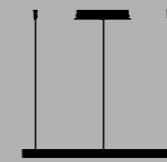

PLANET

PLANET PENDANT - 194



SLICE

SLICE PENDANT - 202

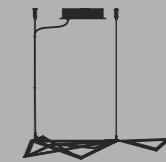

STARLIGHT

STARLIGHT PENDANT - 208

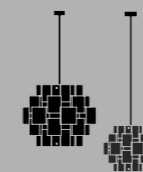

SUN

SUN PENDANT - 214

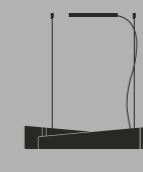

SVEVA

SVEVA PENDANT - 220



TUBE

TUBE PENDANT - 226  
TUBE MICRO PENDANT - 232

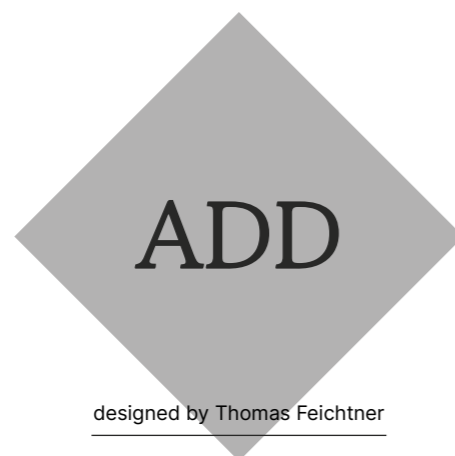

designed by Thomas Feichtner

**A sprinkle of light.  
Ideal for hospitality and  
business settings, Add is a  
play of reflections: the circular  
opening at the top of the  
ceramic shade generates a  
dynamism between the white  
interior and the varnished  
colour exterior.**

Pioggia di luce.

Ideale per spazi ricettivi e business, Add è un gioco di riflessi: l'apertura circolare sulla sommità del paralume in ceramica crea dinamismo tra l'interno bianco e l'esterno rifinito in smalto colorato.



PENDANT LAMPS



ADD pendant lamps | Glossy White and Glossy Bronze shade  
AVANA composable sofa | D04/383 fabric and Umbra Grey legs





## Pendant lamp

ADD

Pendant lamp with pottery shade in different colors with glossy white inside.

Lampada a sospensione con paralume in ceramica in varie finiture con interno smaltato bianco lucido.

MAX 1XE27 100W  
220-240V  
T/fase

CE IP20 

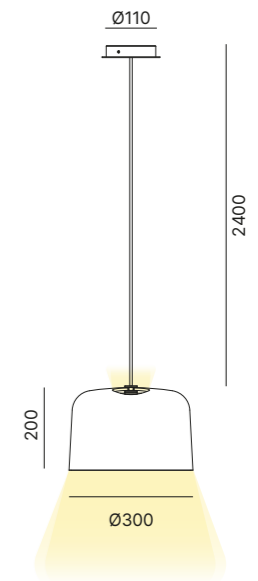

For the icon summary refer to pages 400 - 403 / Per la legenda icone vedere pp. 400 - 403

SHADE FINISH OPTIONS  
FINITURE PARALUME

Glossy White Glossy Bronze Glossy Orange Glossy Blue Glossy Green Matt Clay

CEILING ROSE  
ROSONE

Matt White

DETAILS  
DETTAGLI



**Resplendent pearl.  
Afra is an elegant  
ambience-setting lamp:  
the blown glass sphere  
embraces a hand-woven  
cover, available in unique  
textures that filter light in  
different ways.**

**Perla splendente.  
Afra è una lampada elegante e d'atmosfera: il globo di vetro  
soffiato accoglie una cuffia tessuta a mano, disponibile in  
texture uniche che filtrano la luce in modi sempre diversi.**



PENDANT LAMPS



AFRA pendant lamps | Matt White acid-etched glass shade and Matt White frame  
SIX table | Umbra Grey frame and Invisible White porcelain stoneware top





## Pendant lamp

AFRA

Pendant lamp with white acid etched blown glass shade and powder coated metal frame.

Lampada a sospensione con paralume in vetro soffiato acidato bianco e struttura in metallo verniciato.

MAX 1XE27 100W  
220-240V  
T/fase

CE IP20 

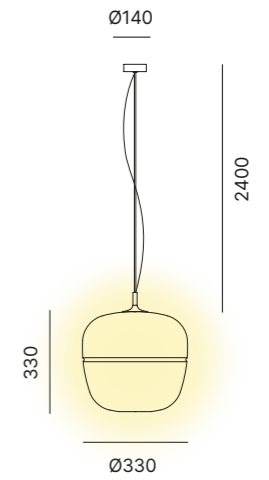

For the icon summary refer to pages 400 - 403 / Per la legenda icone vedere pp. 400 - 403

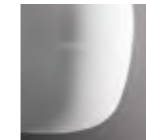
SHADE FINISH OPTIONS  
FINITURE PARALUME

White acid-etched glass

CAP (optional)  
CUFFIA (opzionale)

Beige

Black

CEILING ROSE  
ROSONE

Matt White

FRAME FINISH OPTIONS  
FINITURE STRUTTURA

Matt White



Black Goffratino

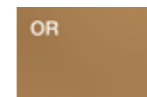

Gold



Bronze



Corten

## Afra collection

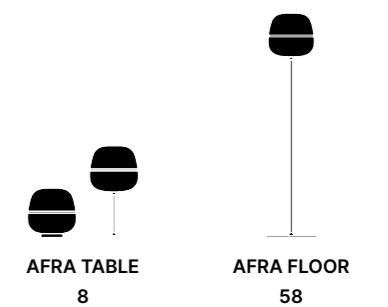



**Legendary allure.  
The honeycomb fabric  
shade of the Babel lamp  
is inspired by the shape  
of the biblical tower, in an  
enveloping spiral around  
the white painted metal  
support.**

**Fascino leggendario.  
Il paralume in tessuto a nido d'ape della lampada Babel si ispira  
alla forma della torre biblica, in una spirale che si avvolge per  
raggiungere il supporto in metallo verniciato bianco.**



PENDANT LAMPS



BABEL pendant lamp | White fabric shade  
X9 meeting table | American Walnut top and Umbra Grey frame

Lighting & Acoustic Collection

DESIGN LIGHTING





### Pendant lamp

# BABEL

Pendant lamp with honeycomb fabric shade.  
Lampada a sospensione con paralume in tessuto a nido d'ape.

MAX 3XE27 60W  
220-240V  
T/fase

CE IP20

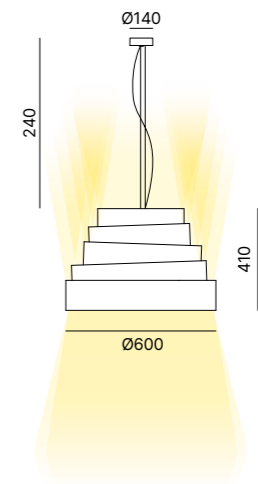

For the icon summary refer to pages 400 - 403 / Per la legenda icone vedere pp. 400 - 403

#### SHADE FINISH OPTIONS FINITURE PARALUME



White



Black

#### CEILING ROSE ROSONE

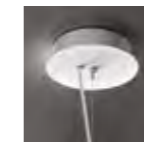

Matt White

### Babel collection



BABEL FLOOR  
64



**Eclectic imagination.  
The trapezoidal shape  
decisively characterises  
settings: in the kitchen,  
meeting rooms or open  
spaces, Blonde is the ceiling  
lamp that is versatile both  
in terms of use and the  
customisation of its finishings.**

Fantasia eclettica.

La forma trapezoidale caratterizza gli ambienti con decisione: in cucina, in sala riunioni o in open space, Blonde è la lampada a soffitto versatile nell'uso e nella personalizzazione delle finiture.



TABLE LAMPS







## Pendant lamp

## BLONDE

Pendant lamp in powder coated aluminium.  
Lampada a sospensione in alluminio verniciato.

Blonde 126	Blonde 166	Blonde 246
67,2W LED	90,3W LED	136,4W LED
7124 lm	9572 lm	14459 lm
110-240V	110-240V	110-240V
2700/3000K	2700/3000K	2700/3000K
CRI80	CRI80	CRI80
All in one	All in one	All in one

CE IP20   24V  MacAdam Step 3 UGR<sub>19</sub>

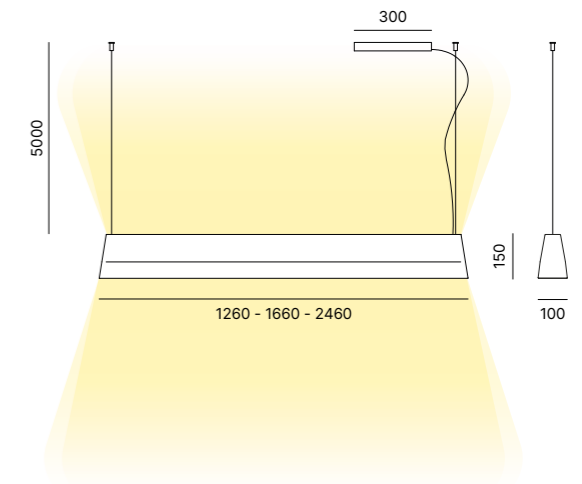

For the icon summary refer to pages 400 - 403 / Per la legenda icone vedere pp. 400 - 403

LAMP FINISH OPTIONS  
FINITURE LAMPADA

Matt White

Brushed  
AlluminiumBlack  
Goffratino

Gold

Bronze

Corten

CEILING ROSE  
ROSONE

Matt White



**Luminous arrangements.  
Minimalistic design,  
customisation possibilities  
and adjustable intensity: CD  
Led combines contemporary  
aesthetics and functionality  
to create large dynamic  
compositions, ideal for business,  
living and hospitality contexts.**

**Accordi luminosi.**

Design minimale, possibilità di personalizzazione e intensità regolabile: CD Led unisce estetica contemporanea e massima funzionalità per creare composizioni dinamiche di grandi dimensioni, ideali per contesti business, living e hospitality.



PENDANT LAMPS





CD LED pendant lamps | Matt Black  
Z1 reception desk | Beige and White lacquered

Lighting & Acoustic Collection





Pendant lamp

CD LED

Pendant lamp with down or up light. Polycarbonate lamp diffuser with transparent or colored PMMA ring.

Lampada da sospensione a luce diretta o indiretta. Diffusore in policarbonato con anello in PMMA trasparente o colorato, struttura in metallo verniciato.

6,7W LED  
110-240V  
2700K  
CRI90  
ON-OFF | T-fase

CE IP20 LED 1250lm MacAdam Step 3  
UGR<sub>19</sub>

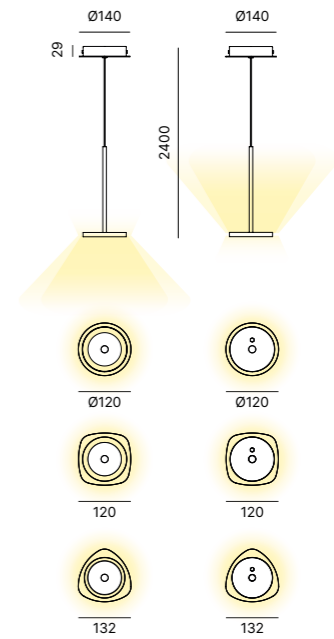

For the icon summary refer to pages 400 - 403 / Per la legenda icone vedere pp. 400 - 403

FINISH OPTIONS  
FINITURE

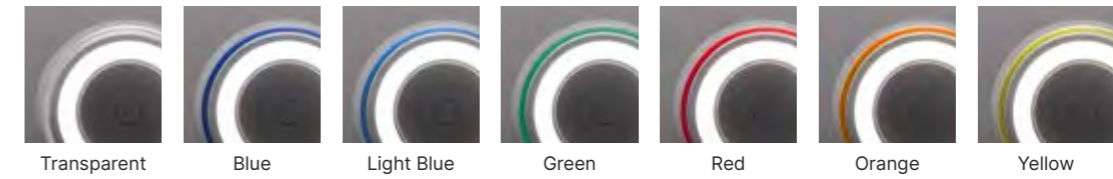

FRAME FINISH OPTIONS  
FINITURE STRUTTURA



Matt Black

CD Led collection

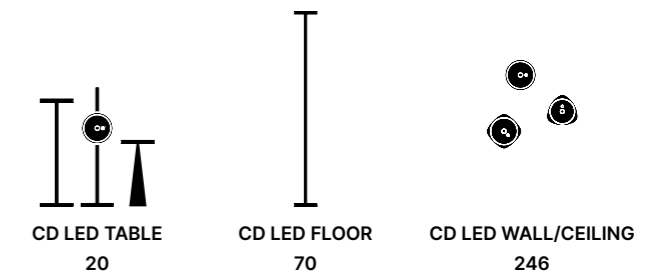



designed by Enrico Franzolini & Vicente García Jimenez

**A toast to light.  
Perfect for restaurants,  
clubs, wineries and hotel  
lobbies, Drink is a refined  
and original lighting  
solution: its aluminium  
upside down chalice  
shape is available in five  
different colours.**

**Brindisi di luce.**

Perfetta per ristoranti, club, enoteche e hall d'albergo,  
Drink è una soluzione di illuminazione raffinata e  
originale: la sua forma in alluminio a calice rovesciato è  
disponibile in cinque colorazioni.



PENDANT LAMPS







Pendant lamp

DRINK

Pendant lamp in powder coated aluminium.  
Lampada a sospensione in alluminio verniciato.

6,3W LED  
220-240V  
2700K  
CRI90  
T/fase | DALI/Push dimm

CE IP20 LED 45-60° 880lm MacAdam Step 3  
UGR<sub>19</sub>

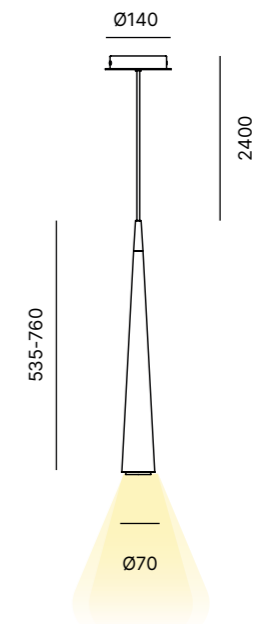

For the icon summary refer to pages 400 - 403 / Per la legenda icone vedere pp. 400 - 403

LAMP AND CEILING ROSE FINISH OPTIONS  
FINITURE LAMPADA E ROSONE



REFLECTOR FINISH OPTIONS  
FINITURE RIFLETTORE



Drink collection



DRINK CEILING  
252



designed by Serena Papait

**Kinetic lighting.**  
**The design of Escape embraces opposites: static and dynamic, light and shade, parallel and perpendicular. The lamp is a formal and conceptual synthesis and can be customised with different colour options for lighting shared settings.**

**Illuminazione cinetica.**  
 Il design di Escape contiene gli opposti: statico e dinamico, luce e ombra, parallelo e perpendicolare. La lampada è una sintesi formale e concettuale, personalizzabile nei colori, per illuminare ambienti condivisi.



PENDANT LAMPS



ESCAPE pendant lamps | Matt White  
X3 meeting table | Oak top and White frame  
CLUE design chair | White polypopylene shell with M02/584 fabric and Matt White frame

Lighting & Acoustic Collection

DESIGN LIGHTING







### Pendant lamp

# ESCAPE

Pendant lamp in powder coated aluminium.  
Matt methacrylate diffuser.  
Lampada a sospensione in alluminio verniciato.  
Diffusore in metacrilato opalino.

45,2W LED  
2700K  
CRI90  
ON-OFF | DALI/Push dimm

CE IP20   5760lm  MacAdam Step 3  
UGR<sub>19</sub>

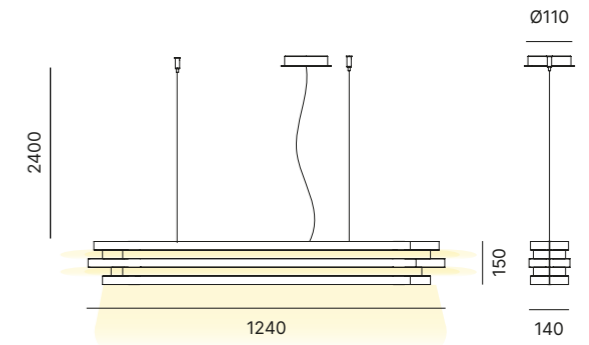

For the icon summary refer to pages 400 - 403 / Per la legenda icone vedere pp. 400 - 403

#### LAMP FINISH OPTIONS FINITURE LAMPADA

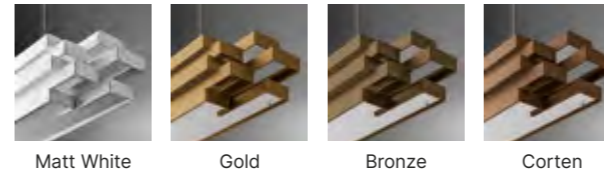

Matt White Gold Bronze Corten

### Escape collection



ESCAPE WALL  
258



designed by Enrico Franzolini

**Natural elements.**  
**Gout draws inspiration from the shape of a water drop: the delicate blown glass diffuses a liquid light and appears crystallised in the act of falling, despite being firmly anchored to the ceiling by a painted metal rod.**

Elementi naturali.

Gout prende ispirazione dalla forma di una goccia d'acqua: il vetro soffiato, delicatissimo, diffonde una luce liquida e sembra cristallizzato nell'atto di cadere, mentre è saldamente ancorato al soffitto da un'asta in metallo verniciato.



PENDANT LAMPS





GOUT pendant lamps | Glossy White and Black glass shade  
Z2 reception desk | Canaletto Walnut and Brown leather



## Pendant lamp

GOUT

Pendant lamp with blown glass diffuser. Powder coated metal stem and ceiling rose.  
Lampada a sospensione con diffusore in vetro soffiato. Asta e rosone in metallo verniciato.

MAX 1XE27 100W  
220-240V  
T/fase

CE IP20 

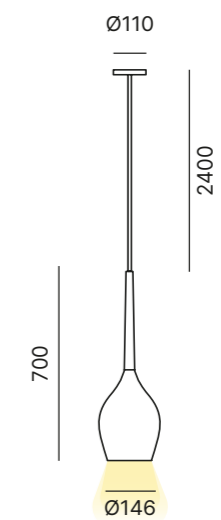

For the icon summary refer to pages 400 - 403 / Per la legenda icone vedere pp. 400 - 403

LAMP FINISH OPTIONS  
FINITURE LAMPADA

Glossy White  
glass



Glossy Black  
glass

CEILING ROSE  
ROSONE

Black  
goffratino



**Innate grace.  
Classical and original,  
Grace features a  
natural linen or black  
cotton shade and  
makes the perfect  
addition to different  
settings.**

**Grazia innata.  
Classica e ricercata, Grace ha un paralume  
in lino naturale o cotone nero e si inserisce  
alla perfezione in diversi contesti.**



PENDANT LAMPS



GRACE pendant lamps | Natural Linen shade  
SEVEN table | Canaletto Walnut top and Bronze frame  
CODE design chair | Walnut varnished solid ash wood shell and legs





## Pendant lamp

GRACE

Pendant lamp with linen or cotton shade.  
Lampada a sospensione con paralume in lino o cotone.

MAX 3XE27 60W  
220-240V  
T/fase

CE IP20 

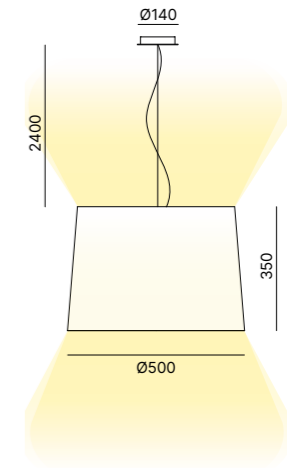

For the icon summary refer to pages 400 - 403 / Per la legenda icone vedere pp. 400 - 403

### SHADE FINISH OPTIONS FINITURE PARALUME



Natural Linen    Black Cotton

### CEILING ROSE ROSONE



Black  
goffratino

## Grace collection

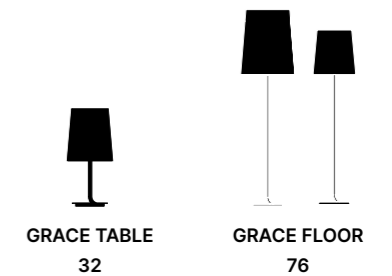

GRACE TABLE  
32

GRACE FLOOR  
76

# HALF MOON

designed by Enrico Franzolini & Vicente García Jimenez

**Eclipse of design.  
Half Moon is simple,  
essential and yet timelessly  
alluring: the colours of the  
shade and the inner part can  
be personalised, bringing  
to life original lamps with a  
modern look.**

**Eclissi di design.**

Half Moon è semplice ed essenziale, ma conserva un fascino senza tempo: i colori del paralume e dell'interno possono essere personalizzati per dare vita a lampade originali dal look moderno.



PENDANT LAMPS



HALF MOON pendant lamps | Natural Linen shade  
SIX table | Noir Desir porcelain stoneware top and Umбра Grey frame  
COVE design chair | B03/185 simil leather and Walnut varnished solid ash wood legs

Lighting & Acoustic Collection

DESIGN LIGHTING





Pendant lamp

HALF MOON

Pendant lamp with linen or cotton shade with white or colored inside.  
 Lampada a sospensione con paralume in lino o cotone, con interno coprente bianco o colorato.

MAX 3XE27 60W  
 220-240V  
 T/fase

CE IP20

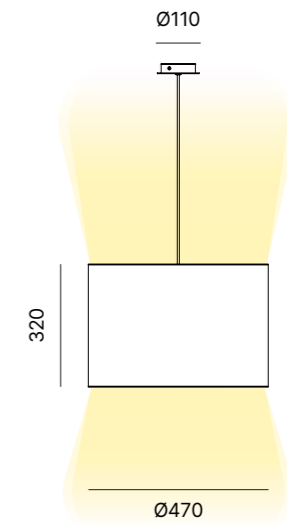

For the icon summary refer to pages 400 - 403 / Per la legenda icone vedere pp. 400 - 403

SHADE FINISH OPTIONS  
 FINITURE PARALUME



Black Cotton White inside    Black Cotton Yellow inside    Black Cotton Orange inside    Black Cotton Fuchsia inside    Natural Linen White inside    Natural Linen Yellow inside    Natural Linen Orange inside    Natural Linen Fuchsia inside

FRAME FINISH OPTIONS  
 FINITURE STRUTTURA

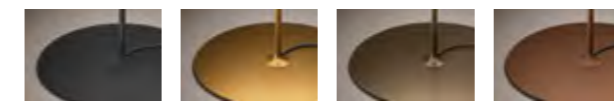

Black Goffratino    Gold    Bronze    Corten

Half Moon collection

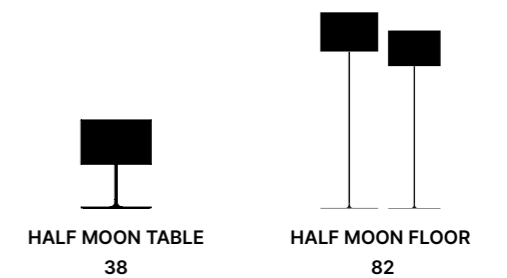

HALF MOON TABLE  
 38

HALF MOON FLOOR  
 82



**Enlightened apparition.  
Mirage is the lighting solution  
suitable for elegant and  
chic settings: the shade  
is the same colour as the  
ceiling rose and features a  
chromed external finishing, to  
amplify light and its exquisite  
reflections.**

**Apparizione lucente.  
Mirage è la soluzione di illuminazione adatta a contesti eleganti  
e chic: il paralume, in tinta col rosone, ha la finitura esterna  
cromata per amplificare la luce e i suoi riflessi preziosi.**



PENDANT LAMPS







## Pendant lamp

## MIRAGE

Pendant lamp in powder coated metal, ceiling rose in matching finish.  
Lampada a sospensione in metallo verniciato con rosone in tinta.

9,6W LED  
220-240V  
2700K  
CRI80  
T/fase

CE IP20   800lm UGR<sub>19</sub>

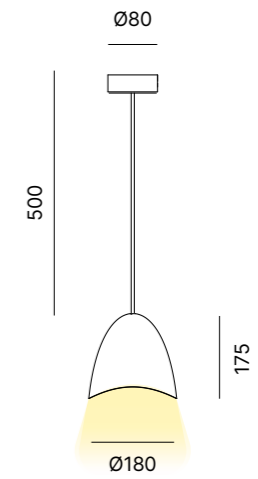

For the icon summary refer to pages 400 - 403 / Per la legenda icone vedere pp. 400 - 403

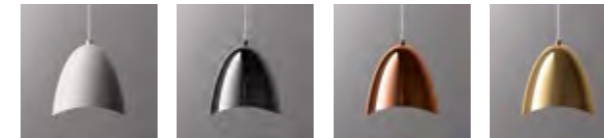
LAMP FINISH OPTIONS  
FINITURE LAMPADA

White

Polished  
ChromePolished  
CopperPolished  
GoldCEILING ROSE  
ROSONE

White

Polished  
ChromePolished  
CopperPolished  
Gold



**Style evolution.**  
**The result of extensive technological research, the fibreglass lampshade of Ola filters light in a unique way through shapes and colours, for material lighting laden with sensations.**

**Stile in divenire.**  
**Frutto di una lunga ricerca tecnologica, il paralume in fibra di vetro di Ola filtra la luce in modo unico attraverso forme e colori, per un'illuminazione materica ricca di sensazioni.**



PENDANT LAMPS



OLA pendant lamps | Gold fibreglass shade  
TWO table | Eucaliptus top and Bronze frame  
CITY DÉCO design chair | E04/487 fabric and Bronze frame

Lighting & Acoustic Collection

DESIGN LIGHTING





Pendant lamp

OLA

Pendant lamp with fibreglass shade.  
Lampada a sospensione con paralume in fibra di vetro.

MAX 3XE27 60W  
220-240V  
T/fase

CE IP20 

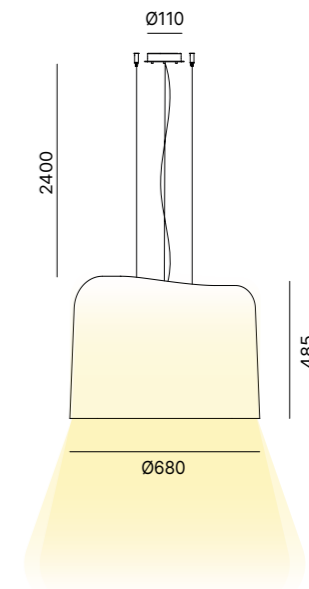

For the icon summary refer to pages 400 - 403 / Per la legenda icone vedere pp. 400 - 403

SHADE FINISH OPTIONS  
FINITURE PARALUME

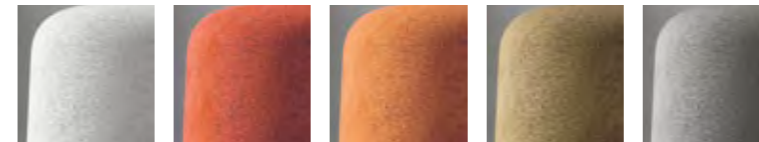

White fibreglass   Red fibreglass   Orange fibreglass   Gold fibreglass   Silver fibreglass

CEILING ROSE  
ROSONE



Black goffratino   White

Ola collection

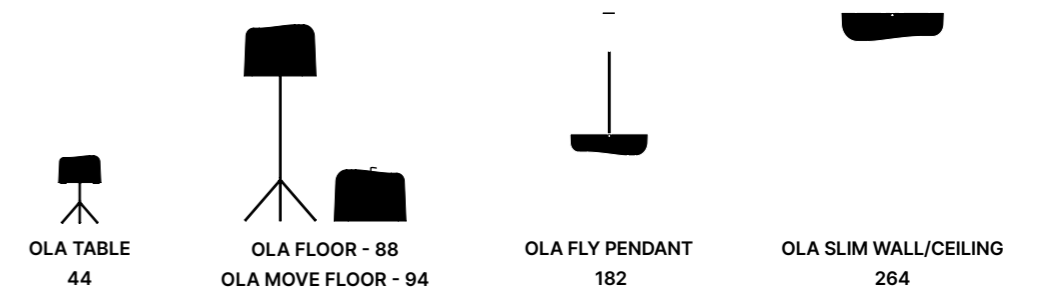



**Dreamy forms.  
Ideal for business and  
hospitality settings, Ola Fly  
reinterprets the tonalities  
of light through the colours  
of its fibreglass shade and  
is available with white, red,  
orange, gold and silver  
finishings.**

Forme sognanti.  
Ideale per ambienti business e hospitality, Ola Fly reinterpreta le  
tonalità della luce attraverso i colori del suo paralume in fibra di  
vetro, nelle finiture bianco, rosso, arancio, oro e argento.



PENDANT LAMPS





Pendant lamp

Pendant lamp with fibreglass shade.  
Lampada a sospensione con paralume in fibra di vetro.

MAX 3XE27 60W  
220-240V  
T/fase

CE IP20 

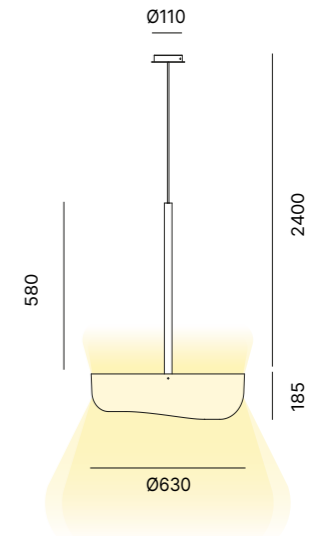

For the icon summary refer to pages 400 - 403 / Per la legenda icone vedere pp. 400 - 403

SHADE FINISH OPTIONS  
FINITURE PARALUME



CEILING ROSE  
ROSONE



Ola collection

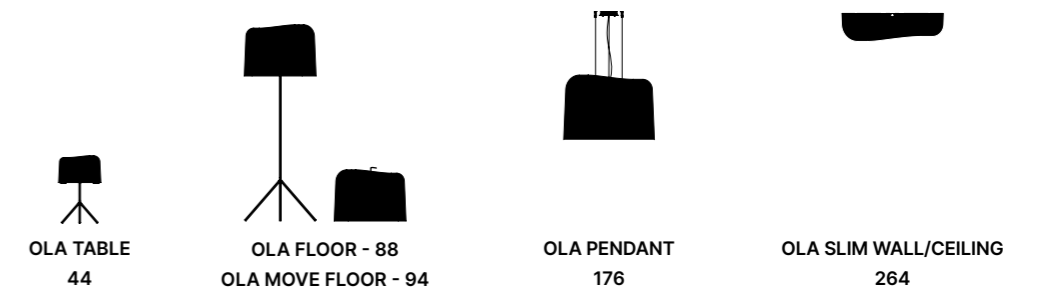

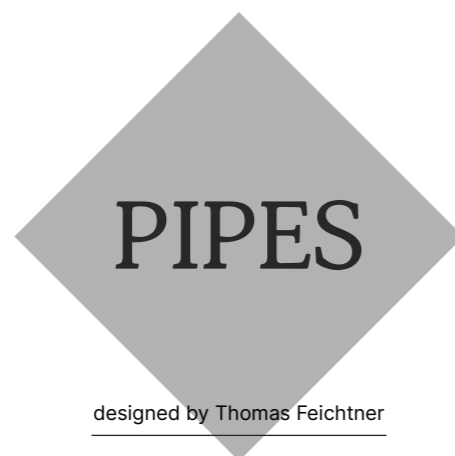

**Gleaming chrome.**  
**Pipes features a tubular structure,**  
**consisting of curved and woven**  
**aluminium, available in four**  
**tonalities: white, bronze, gold**  
**and corten. It reigns supreme in**  
**dining rooms, reception areas and**  
**convivial settings.**

**Chioma brillante.**

Pipes ha una struttura tubolare, formata da alluminio curvato e intrecciato, disponibile in quattro tonalità: bianco, bronzo, oro e corten. È la protagonista di sale da pranzo, aree reception e luoghi conviviali.



PENDANT LAMPS







## Pendant lamp

## PIPES

Pendant lamp made by powder coated aluminium pipes.  
Lampada a sospensione composta da tubi in alluminio verniciati.

17W LED  
2700K  
CRI80  
DALI/Push dimm

CE IP20   1400lm UGR<sub>19</sub>

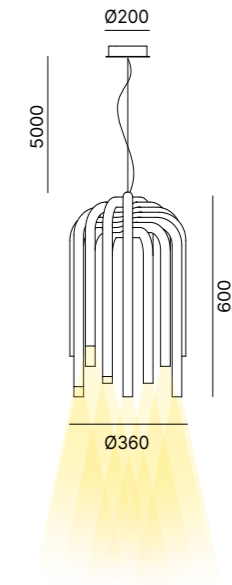

For the icon summary refer to pages 400 - 403 / Per la legenda icone vedere pp. 400 - 403

### SHADE FINISH OPTIONS FINITURE PARALUME

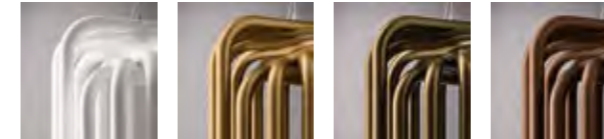

Matt White

Gold

Bronze

Corten

### CEILING ROSE ROSONE



Matt White



**Suspended galaxy.  
Light propagates in Planet  
from the curved aluminium  
circle, available in 3 diameter  
sizes and different finishings,  
resulting in the perfect  
lighting for boardroom and  
meeting interiors.**

**Galassia sospesa.  
La luce di Planet si propaga dal cerchio in alluminio calandrato,  
disponibile in 3 misure di diametro e in diverse finiture:  
l'illuminazione perfetta per spazi di rappresentanza e di incontro.**



PENDANT LAMPS





196

PLANET pendant lamps | Gold  
Z1 reception desk | Umbra Grey and Silk Grey lacquered

The LED lighting, which is both direct and indirect, resides in the circular profile, and it is equipped with an intensity-adjustable diffuser.

L'illuminazione a led, diretta e indiretta, risiede nel profilo circolare, il quale è dotato di diffusore regolabile in intensità.



197

PLANET pendant lamps | Matt White  
CELSIUS chair | E02/445 fabric and Chrome legs  
FIVE table | White top and frame

Lighting & Acoustic Collection

DESIGN LIGHTING

198

199





## Pendant lamp

## PLANET

Pendant lamp in powder coated aluminium.  
Lampada a sospensione in alluminio verniciato.

Planet 70	Planet 90	Planet 110
2700K	2700K	2700K
CRI90	CRI90	CRI90
ON-OFF   All in one	ON-OFF   All in one	ON-OFF   All in one
Down light	Down light	Down light
28W LED	35W LED	46W LED
4548 lm	5880 lm	7696lm
Up/Down light	Up/Down light	Up/Down light
54W LED	67W LED	88W LED
9096 lm	11760lm	15392lm

CE IP20    24V  MacAdam Step 3

For the icon summary refer to pages 400 - 403 / Per la legenda icone vedere pp. 400 - 403

SHADE FINISH OPTIONS  
FINITURE PARALUME

Matt White

Gold

Bronze

Corten

CEILING ROSE  
ROSONE

Matt White

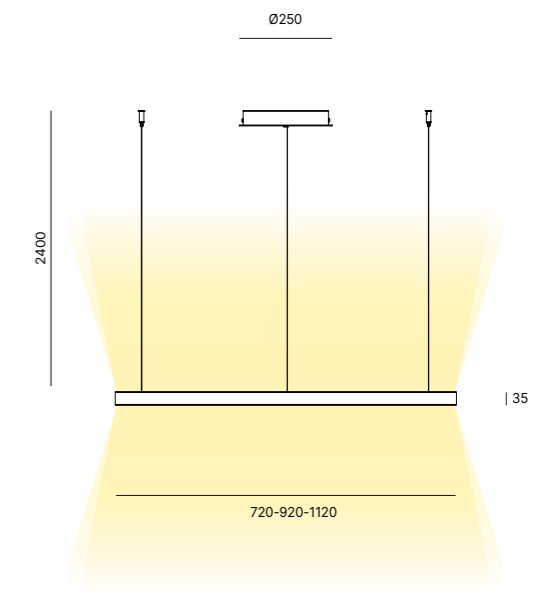



designed by Enrico Franzolini

**Cut of light.**  
**Slice features a clean-cut and decisive aluminium profile: it diffuses punctual light and can be articulated in compositions consisting of several items or a single lamp, for lighting in living, hospitality and business settings.**

Taglio di luce.

Slice ha un profilo in alluminio netto e deciso: diffonde una luce puntuale e si può articolare in composizioni a più pezzi o con lampada singola, per illuminare spazi living, hospitality e business.



PENDANT LAMPS



SLICE pendant lamps | Gold







## Pendant lamp

## SLICE

Pendant lamp in powder coated aluminium.  
Lampada a sospensione in alluminio verniciato.

6,3W LED  
220-240V  
2700K  
CRI90  
T/fase | DALI/Push dimm

CE IP20   880lm  MacAdam Step 3  
UGR<sub>19</sub>

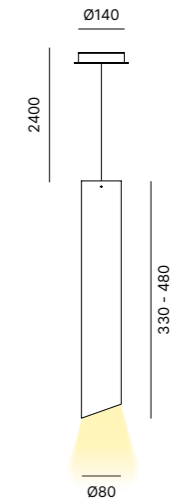

For the icon summary refer to pages 400 - 403 / Per la legenda icone vedere pp. 400 - 403

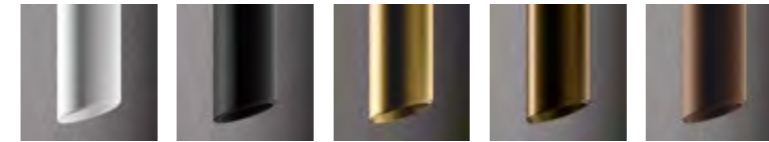
LAMP FINISH OPTIONS  
FINITURE LAMPADA

Matt White

Black  
Goffratino

Gold

Bronze

Corten

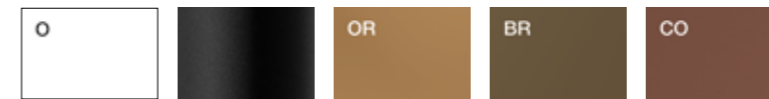
CEILING ROSE  
ROSONEBlack  
GoffratinoREFLECTOR FINISH OPTIONS  
FINITURE RIFLETTORE

Matt White

Black Goffratino

Gold

Bronze

Corten

## Slice collection

SLICE WALL/CEILING  
276

# STARLIGHT

designed by Serena Papait

**Slender elegance.  
Starlight is a veritable  
geometric sculpture with  
soft and indirect led lighting.  
It creates plays of shadows  
and lights and is suitable  
for enhancing a suffused  
ambience in refined settings.**

**Esile eleganza.  
Starlight è una vera e propria scultura geometrica con  
illuminazione a led soft e indiretta. Crea giochi di ombre e riflessi,  
adatti a suggerire atmosfere soffuse per ambienti ricercati.**



PENDANT LAMPS





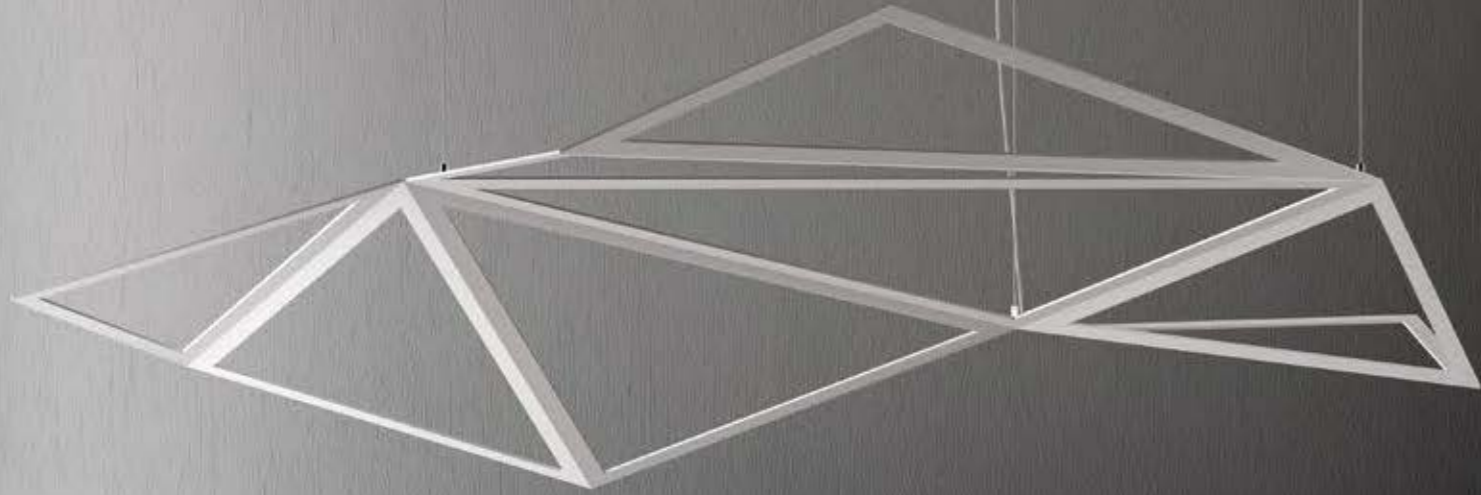

Pendant lamp

STARLIGHT

Pendant lamp in powder coated aluminium, up light.  
Lampada a sospensione in alluminio verniciato, luce indiretta.

Starlight	Starlight Giant
22W LED	47W LED
2700 lm	5400 lm
2700K	2700K
CRI90	CRI90
DALI/Push dimm	DALI/Push dimm

CE IP20 LED UGR<sub>19</sub>

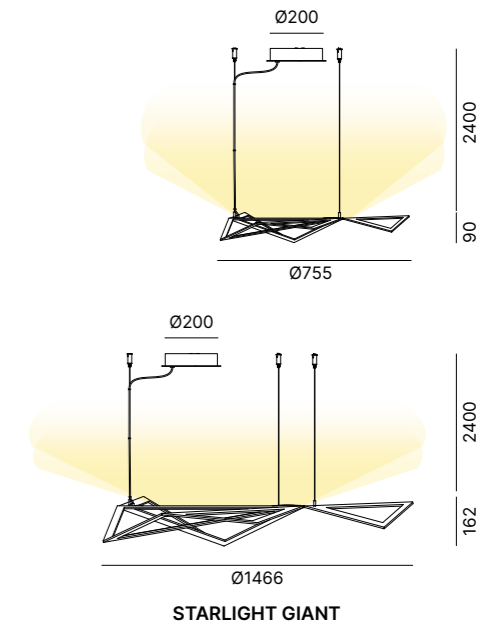

For the icon summary refer to pages 400 - 403 / Per la legenda icone vedere pp. 400 - 403

LAMP FINISH OPTIONS  
FINITURE LAMPADA

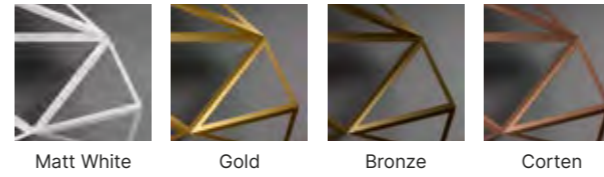

CEILING ROSE  
ROSONE



Matt White

Starlight collection

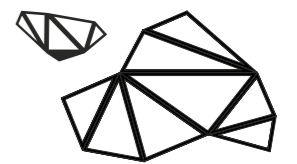

STARLIGHT WALL  
282

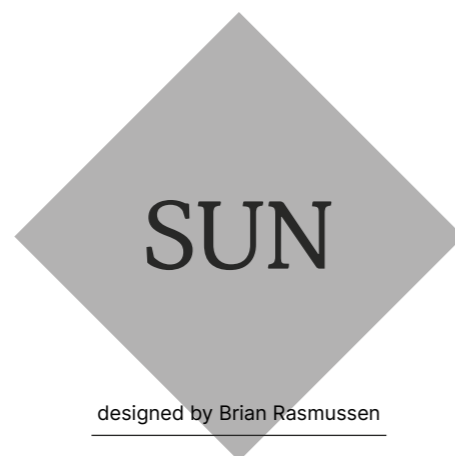

designed by Brian Rasmussen

**Solar creativity.  
Sun multiplies, fragments  
and adds dynamism to light  
through the eccentric woven  
fabric shade, customisable in  
three tonalities. The suspended  
version is available in two  
sizes, adding character to  
contemporary settings.**

Creatività solare.

Sun moltiplica, frammenta e rende dinamica la luce attraverso l'eccentrico paralume in tessuto lavorato, personalizzabile in tre tonalità. La versione a sospensione è disponibile in due dimensioni, per dare carattere ad ambienti contemporanei.



PENDANT LAMPS



SUN pendant lamps | Black fabric shade  
X9 meeting table | Elm top with Anthracite leather inlay, Umbra Grey frame  
DIADE executive chair | P01/172 leather





Pendant lamp

SUN

Pendant lamp with fabric shade.  
Lampada a sospensione con paralume in tessuto.

Sun 50	Sun 75
MAX 1XE27 100W	MAX 3XE27 60W
220-240V	220-240V
T/fase	T/fase

CE IP20 

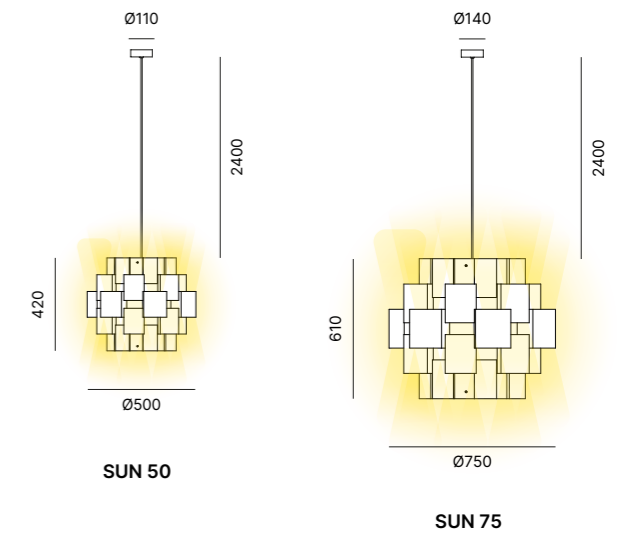

For the icon summary refer to pages 400 - 403 / Per la legenda icone vedere pp. 400 - 403

SHADE FINISH OPTIONS  
FINITURE PARALUME

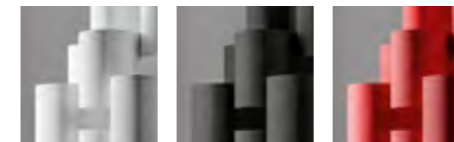

White fabric    Black fabric    Red fabric

CEILING ROSE  
ROSONE



Matt White

Sun collection

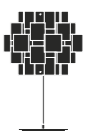

SUN TABLE  
50



**Diffused allure.  
Sveva is the queen in any  
setting, delivering pleasant  
and diffused light in business  
and hospitality interiors  
while seamlessly matching  
different styles thanks to  
customisation options for its  
finishings.**

**Charme diffuso.  
Sveva è la regina di ogni spazio: getta una luce garbata e diffusa  
su ambienti business e hospitality e si intona a diversi contesti  
grazie alla possibilità di personalizzare le finiture.**



PENDANT LAMPS







## Pendant lamp

SVEVA

Pendant lamp in powder coated aluminium.

Matt methacrylate diffuser.

Lampada a sospensione in alluminio verniciato.



Diffusore in metacrilato opalino.

40W LED

3000K

CRI90

ON-OFF | All in one

CE IP20   24V 5922lm  MacAdam Step 3

UGR<sub>19</sub>

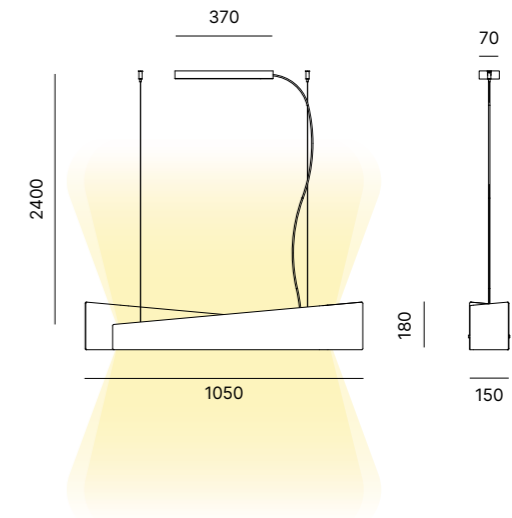

For the icon summary refer to pages 400 - 403 / Per la legenda icone vedere pp. 400 - 403

LAMP FINISH OPTIONS  
FINITURE LAMPADA

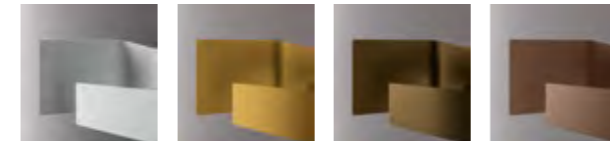

Matt White

Gold

Bronze

Corten

DIFFUSER  
DIFFUSORE



PMMA

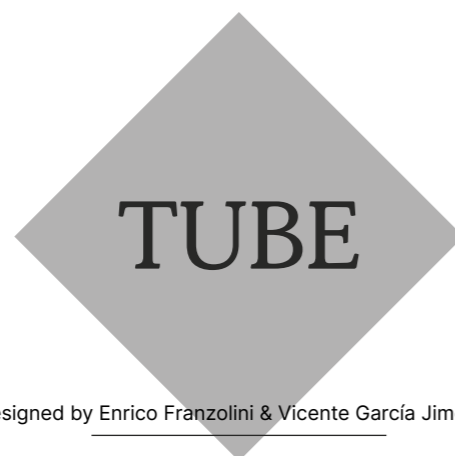

designed by Enrico Franzolini & Vicente García Jimenez

**Winning simplicity.**  
**Tube is an equation that  
 resolves all project design  
 and aesthetic requirements:  
 80 mm diameter, 2 available  
 lengths and a choice of  
 5 finishings and infinite  
 modulation options, with one  
 or more lamps.**

Semplicità vincente.

Tube è un'equazione che risolve ogni esigenza progettuale ed estetica: 80 mm di diametro, 2 lunghezze disponibili, 5 finiture tra cui scegliere e infinite possibilità di modulazione, con lampada singola o più lampade.



PENDANT LAMPS







Pendant lamp

TUBE

Pendant lamp in powder coated aluminium.  
Lampada a sospensione in alluminio verniciato.

6,3W LED  
220-240V  
2700K  
CRI90  
T/fase | DALI/Push dimm

CE IP20 LED 45-60° 880lm MacAdam Step 3 UGR<sub>19</sub>

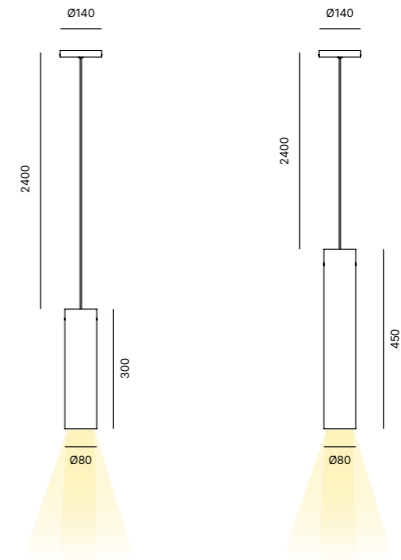

For the icon summary refer to pages 400 - 403 / Per la legenda icone vedere pp. 400 - 403

SHADE FINISH OPTIONS  
FINITURE PARALUME

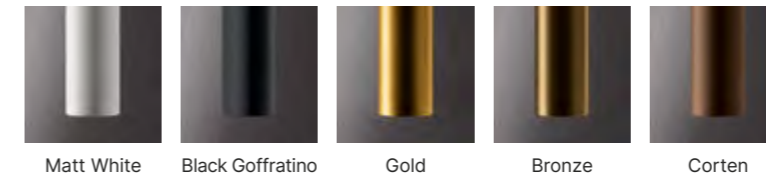

CEILING ROSE  
ROSONE

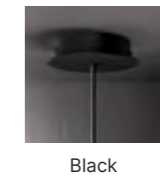

REFLECTOR FINISH OPTIONS  
FINITURE RIFLETTORE



Tube collection

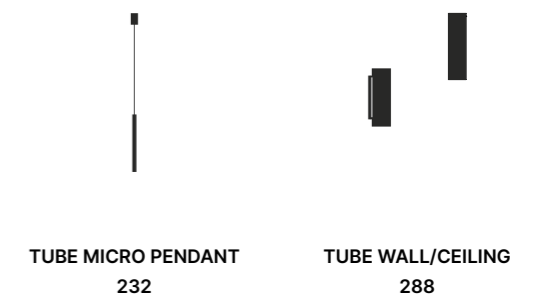

# TUBE MICRO

designed by Quadrifoglio Group

**Slender soul.**  
**Tube Micro illuminates residential and professional settings with versatile compositions: cascades, sprinkles, duets and monologues of light inspired by lightness and elegance. The punctual light showcases any furnishing detail.**

**Anima sottile.**  
**Tube Micro illumina ambienti residenziali e professionali con composizioni versatili: cascate, piogge, duetti e monologhi di luce all'insegna della leggerezza e dell'eleganza. La luce puntuale rende protagonisti i dettagli di ogni arredo.**



TABLE LAMPS





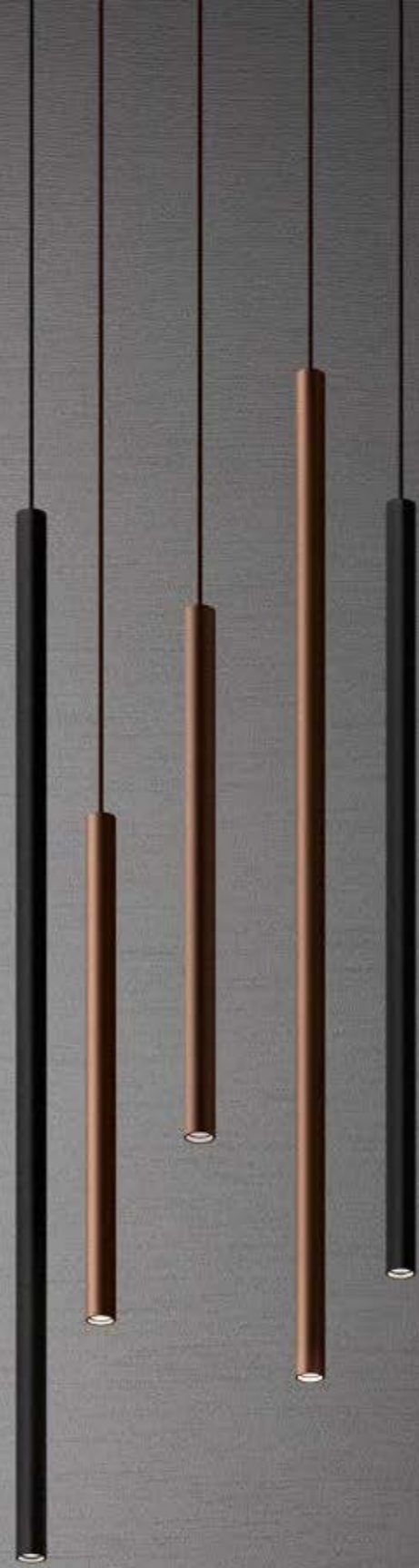

Pendant lamp

TUBE MICRO

Pendant lamp in powder coated aluminium.  
Lampada a sospensione in alluminio verniciato.

1,5W LED  
2700K  
CRI90  
ON-OFF

CE IP20   150lm  MacAdam Step 6 UGR<sub>19</sub>



For the icon summary refer to pages 400 - 403 / Per la legenda icone vedere pp. 400 - 403

SHADE FINISH OPTIONS  
FINITURE PARALUME

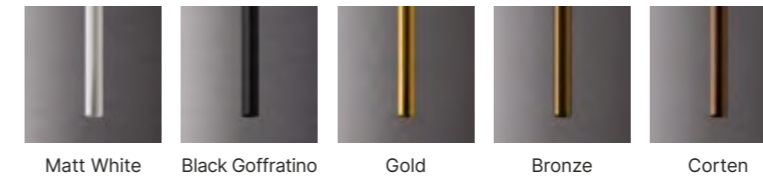

Matt White Black Goffratino Gold Bronze Corten

Tube collection

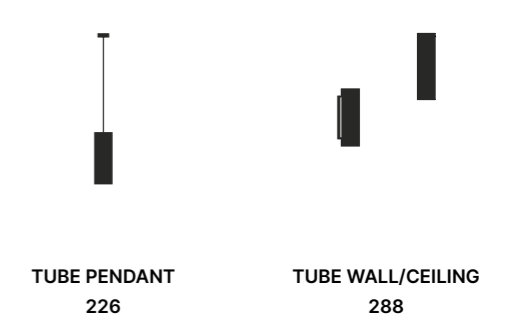

TUBE PENDANT  
226

TUBE WALL/CEILING  
288

# Wall/Ceiling Lamps

Decorative Lighting

Lighting & Acoustic Collection



## Wall/Ceiling lamps



ALALUNGA  
ALALUNGA WALL - 240



CD LED  
CD LED WALL - 246



DRINK  
DRINK CEILING - 252



ESCAPE  
ESCAPE WALL - 258



OLA SLIM  
OLA SLIM WALL/CEILING - 264



SHADOW  
SHADOW WALL - 270



SLICE  
SLICE CEILING - 276

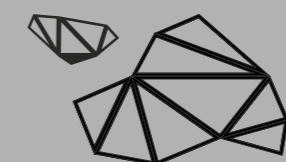

STARLIGHT  
STARLIGHT WALL - 282



TUBE  
TUBE WALL/CEILING - 288



TUPLA  
TUPLA WALL - 296



TURN ME!  
TURN ME! WALL - 302

DESIGN LIGHTING

# ALALUNGA

designed by Enrico Franzolini

**The beat of a wing.  
Alalunga is a wall-hung painted metal appliqué available in two sizes and four deluxe finishings. Its elegant and luminous presence enhances contemporary and exclusive settings with delicate lighting.**

**Battito d'ali.**

Alalunga è un'applique da parete in metallo verniciato, disponibile in due dimensioni e quattro finiture deluxe. La sua presenza, leggiadra e luminosa, valorizza ambienti contemporanei ed esclusivi con un'illuminazione leggera.

  
WALL/CEILING LAMPS



ALALUNGA wall lamp | Bronze  
BLONDE pendant lamp | Bronze  
NINE table | Ebony top and Umbra Grey legs

Lighting & Acoustic Collection



242

243

DESIGN LIGHTING



## Wall lamp

## ALALUNGA

Wall lamp in powder coated metal.  
Lampada a parete in metallo verniciato.

Alalunga Mini	Alalunga
9,2W LED	10,9W LED
720 lm	1300 lm
220-240V	110-240V
2700K	2700K
CRI90	CRI90
T/fase	T/fase   DALI/Push dimm

CE IP20  UGR<sub>19</sub>

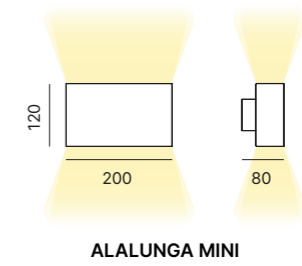

ALALUNGA MINI

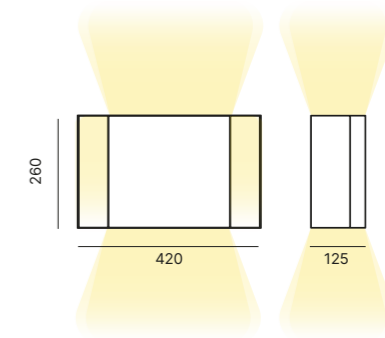

ALALUNGA

For the icon summary refer to pages 400 - 403 / Per la legenda icone vedere pp. 400 - 403

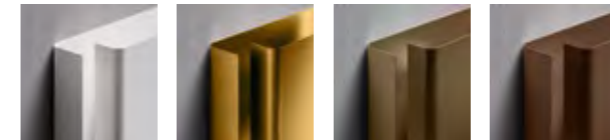
SHADE FINISH OPTIONS  
FINITURE PARALUME

Matt White

Gold

Bronze

Corten



**Intense constellations.  
Refined and shaded wall  
lighting: CD Led in the appliqué  
version is available in numerous  
colours and three shapes,  
modulable in single or multiple  
compositions that are always  
new and surprising.**

**Costellazioni intense.  
Un'illuminazione a parete raffinata e sfumata: CD Led in versione applique  
è disponibile in numerosi colori e in tre forme, modulabili in composizioni,  
singole o plurime, sempre nuove e sorprendenti.**



CD LED wall lamps | Matt Black  
CITY LOUNGE armchair | B03/185 simil leather and Black base  
MELBOURNE side table | Umbra Grey lacquered top and Oak varnished solid ash wood legs





Wall lamp

CD LED

Polycarbonate lamp diffuser with transparent or colored PMMA ring, powder coated metal frame.  
 Diffusore in policarbonato con anello in PMMA trasparente o colorato, struttura in metallo verniciato.

8,4W LED  
 220-240V  
 2700K  
 CRI90  
 ON-OFF | T/fase

CE IP20 LED 24V 1250lm MacAdam Step 3  
 UGR<sub>19</sub>

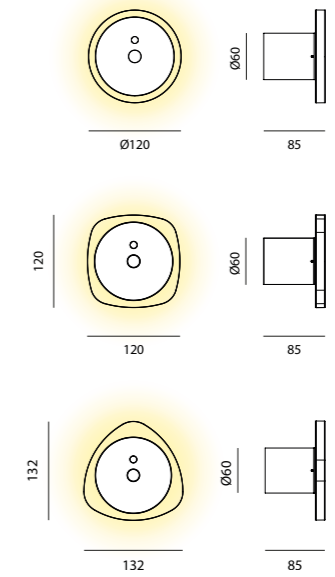

For the icon summary refer to pages 400 - 403 / Per la legenda icone vedere pp. 400 - 403

FINISH OPTIONS  
 FINITURE

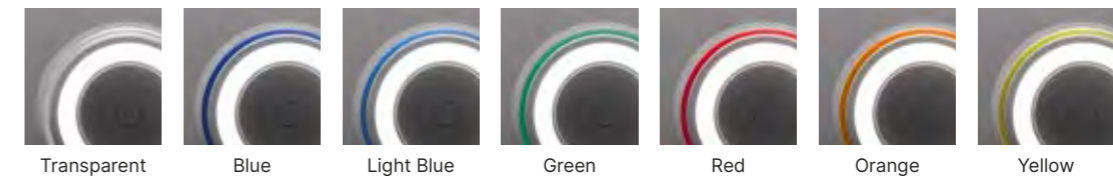

FRAME FINISH OPTIONS  
 FINITURE STRUTTURA



Matt Black

CD Led collection

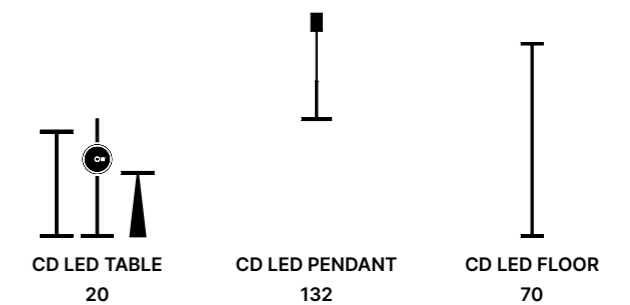



designed by Enrico Franzolini & Vicente García Jimenez

**Convivial lighting.  
Drink is the perfect pendant  
lamp for restaurants, hotels,  
wineries, clubs and other  
shared spaces. The aluminium  
structure is orientable and  
adjustable according to  
needs, for lighting tables and  
seating.**

**illuminazione conviviale.**

Drink è la lampada a sospensione perfetta per ristoranti, hotel, enoteche, club e altri spazi di condivisione. La struttura in alluminio è orientabile e regolabile a seconda delle esigenze, per illuminare tavoli e sedute.



WALL/CEILING LAMPS









## Ceiling lamp

DRINK

Ceiling lamp in powder coated aluminium.  
Lampada a soffitto in alluminio verniciato.

6,3W LED  
220-240V  
2700K  
CRI90  
T/fase | DALI/Push dimm

CE IP20   880lm  MacAdam Step 3  
UGR<sub>19</sub>

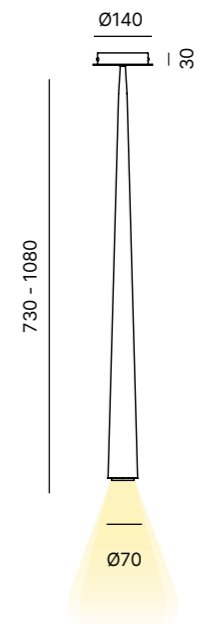

For the icon summary refer to pages 400 - 403 / Per la legenda icone vedere pp. 400 - 403

### LAMP AND CEILING ROSE FINISH OPTIONS FINITURE LAMPADA E ROSONE



### REFLECTOR FINISH OPTIONS FINITURE RIFLETTORE



## Drink collection



DRINK PENDANT  
140



**A play of planes.**  
**Escape is available in different colours and three sizes, from big to small. Its light glides from one level to another, creating a dynamic and vibrant effect, ideal for lighting in residential and hospitality settings.**

**Gioco di piani.**  
 Escape è disponibile in diversi colori e in tre dimensioni, dalla più compatta alla più estesa: la sua luce scivola da un livello all'altro creando un effetto dinamico e vibrante, ideale per illuminare ambienti residenziali e spazi ricettivi.

WALL/CEILING LAMPS





Wall lamp

Wall lamp in powder coated aluminium.

Matt methacrylate diffuser.

Lampada a parete in alluminio verniciato. Diffusore in metacrilato opalino.

Escape Cube	Escape 50	Escape 80
8,7W LED	12,5W LED	22,6W LED
800 lm	1440 lm	2880 lm
220-240V	220-240V	220-240V
2700K	2700K	2700K
CRI80	CRI90	CRI90
T/fase	T/fase	T/fase

CE IP20 LED MacAdam Step 3 UGR<sub>19</sub>

For the icon summary refer to pages 400 - 403 / Per la legenda icone vedere pp. 400 - 403

LAMP FINISH OPTIONS  
FINITURE LAMPADA

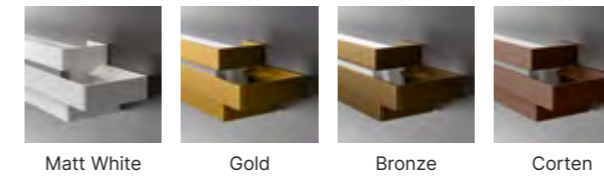

Matt White Gold Bronze Corten

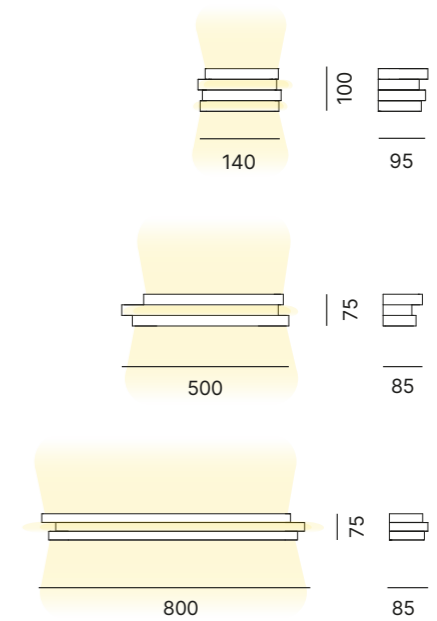

Escape collection

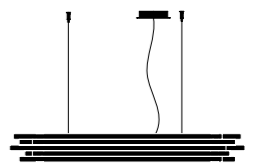

ESCAPE PENDANT  
146

# OLA SLIM

designed by Enrico Franzolini

**Lunar Ambience.  
Light becomes tactile  
perception thanks to the  
fibreglass shade filter of  
Ola Slim, the wall lamp  
that evokes suggestions  
from other worlds, in any  
interior.**

**Atmosfere lunari.  
La luce si fa percezione tattile grazie al filtro del paralume in  
fibra di vetro di Ola Slim, la lampada a parete capace di evocare  
suggerimenti di altri mondi in ogni ambiente.**

  
WALL/CEILING LAMPS





OLA SLIM wall/ceiling lamps | White fibreglass shade  
AVANA composable sofa | D04/387 fabric and Umbra Grey legs  
MIAMI side table and pot | Emperador Lucido porcelain stoneware top and Bronze frame



Wall/Ceiling lamp

OLA SLIM

Wall/Ceiling lamp with fibreglass shade.  
Lampada a parete/soffitto con paralume in fibra di vetro.

MAX 3XE27 60W  
220-240V  
T/fase

CE IP20 ⚡

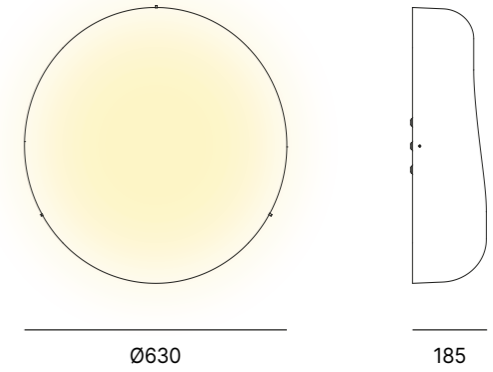

For the icon summary refer to pages 400 - 403 / Per la legenda icone vedere pp. 400 - 403

SHADE FINISH OPTIONS  
FINITURE PARALUME



White fibreglass   Red fibreglass   Orange fibreglass   Gold fibreglass   Silver fibreglass

Ola collection

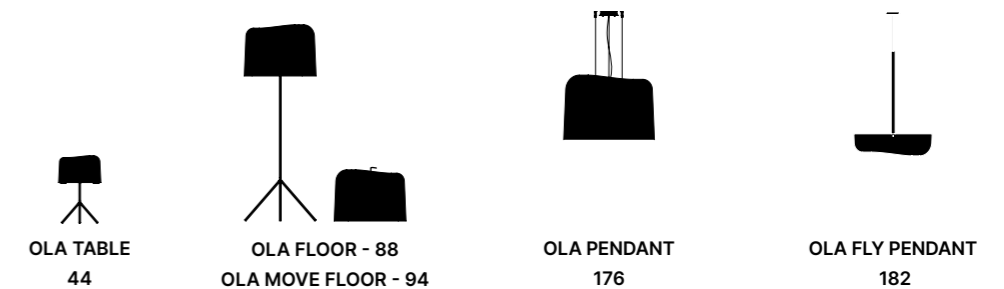



**Shadow inclinations.  
Shadow shields and  
unleashes light according to  
need, thanks to the orientable  
diffuser and dimmer device  
for adjusting intensity. Light  
and shade coexist in an ever-  
active balance.**

**Inclinazioni d'ombra.  
Shadow schermo e libera la luce a seconda delle esigenze  
grazie al diffusore orientabile e al dispositivo dimmer per  
regolare l'intensità. Nel suo design luce e ombra convivono  
in un equilibrio sempre attivo.**

  
WALL/CEILING LAMPS





Lighting | POLI | C...

DESIGN | LIGHTING

272

273

SHADOW wall lamps | Gold  
ARTE sofa | E04/493 fabric

## Wall lamp

## SHADOW

Wall lamp in powder coated metal.  
Lampada a parete in metallo verniciato.

Shadow 33	Shadow 63
17W LED	25,5W LED
1600 lm	2400 lm
220-240V	220-240V
2700K	2700K
CRI80	CRI80
T/fase	T/fase

CE IP20  UGR<sub>19</sub>

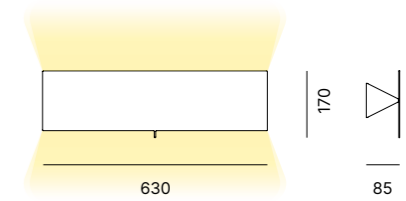
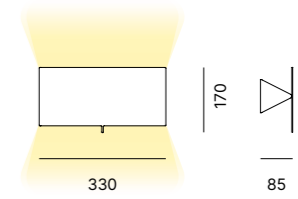

For the icon summary refer to pages 400 - 403 / Per la legenda icone vedere pp. 400 - 403

SHADE FINISH OPTIONS  
FINITURE PARALUME

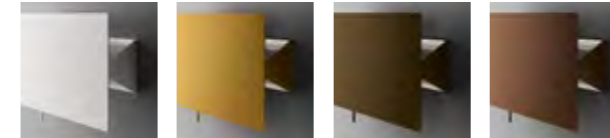

Matt White

Gold

Bronze

Corten



designed by Enrico Franzolini & Vicente García Jimenez

**Decisive character.  
Cylindrical shape and direct  
light: Slice is a lamp with  
a decisive personality and  
is fitted directly onto the  
ceiling without a rose, ideal  
for modern settings with an  
minimalistic style.**

**Carattere deciso.**

**Forma cilindrica e luce diretta: Slice è una lampada dalla personalità risoluta, si applica direttamente al soffitto senza l'ausilio di un rosone ed è ideale per contesti dallo stile moderno e minimal.**

  
 WALL/CEILING LAMPS





278

SLICE ceiling lamps | Black Goffratino lamp with Gold reflector  
 LIBRERIA bookshelves | Umbra Grey lacquer  
 CLEOPAS armchair and ottoman | E03/463 fabric and Umbra Grey base

The diagonal cut of light in Slice provides lighting that is punctual and pleasant in interiors. The lamp is available in white, embossed black, gold, bronze and corten, to match different styles.

Il taglio diagonale della luce di Slice permette di illuminare gli ambienti in modo puntuale e piacevole. La lampada è disponibile in bianco, nero goffratino, oro, bronzo e corten, per intonarsi a stili diversi.



279

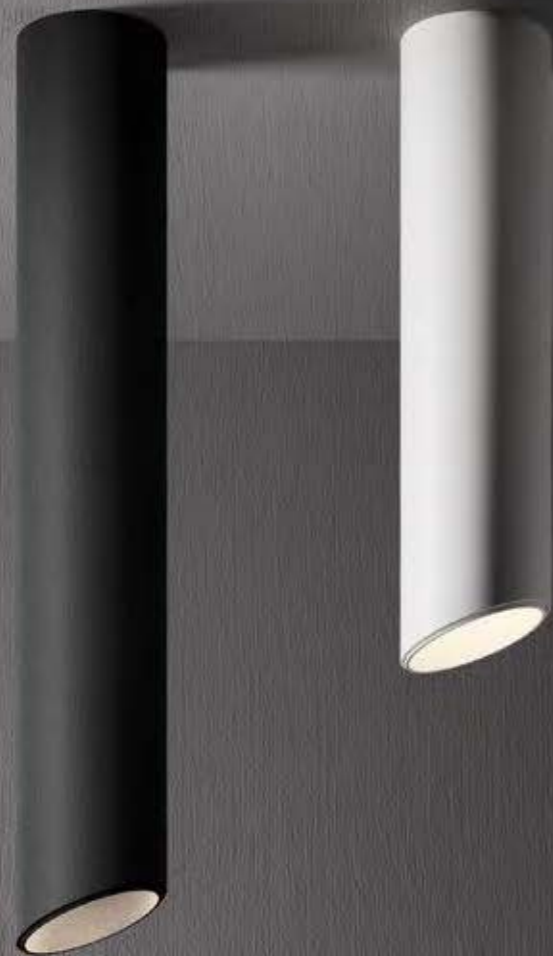

## Ceiling lamp

SLICE

Ceiling lamp in powder coated aluminium.  
Lampada a soffitto in alluminio verniciato.

6,3W LED  
220-240V  
2700K  
CRI90  
T/fase | DALI/Push dimm

CE IP20   880lm  MacAdam Step 3  
UGR<sub>19</sub>

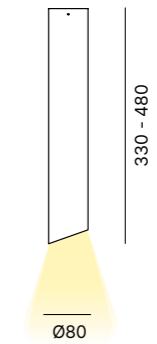

For the icon summary refer to pages 400 - 403 / Per la legenda icone vedere pp. 400 - 403

LAMP FINISH OPTIONS  
FINITURE LAMPADA

Matt White

Black  
Goffratino

Gold

Bronze

Corten

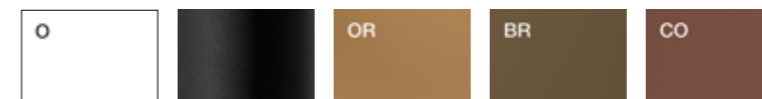
REFLECTOR FINISH OPTIONS  
FINITURE RIFLETTORE

Matt White

Black Goffratino

Gold

Bronze

Corten

## Slice collection



SLICE PENDANT  
202

# STARLIGHT

designed by Serena Papait

**Configurable geometries. Starlight is available in two sizes and numerous compositions: its changeable shape illuminates residential and professional settings with radiant reflections and plays of indirect light, for a suffused and soft effect.**

Geometrie componibili.

Starlight è disponibile in due dimensioni e numerose composizioni: la sua forma mutevole illumina ambienti residenziali e professionali con riflessi luminosi e giochi di luce indiretti, per un effetto di soffusa morbidezza.

  
 WALL/CEILING LAMPS



STARLIGHT GIANT wall lamps | Bronze  
AVANA composable sofa | M01/556 fabric, Eucalyptus table top and Umbra Grey legs  
MIAMI side table | Fokos Terra porcelain stoneware top and Umbra Grey frame

Lighting & Acoustic Collection

284



DESIGN LIGHTING

285





Wall lamp

STARLIGHT

Wall lamp in powder coated aluminium.  
Lampada a parete in alluminio verniciato.

**Starlight**

22W LED  
2000 lm  
110-240V  
2700K  
CRI90  
ON-OFF

CE IP20    
UGR<sub>19</sub>

**Starlight Giant**

47W LED  
5400 lm  
2700K  
CRI90  
DALI/Push dimm

CE IP20    
UGR<sub>19</sub>

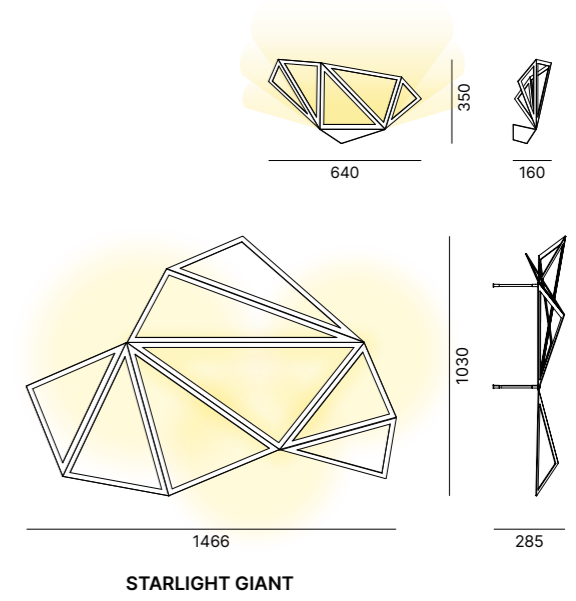

For the icon summary refer to pages 400 - 403 / Per la legenda icone vedere pp. 400 - 403

LAMP FINISH OPTIONS  
FINITURE LAMPADA

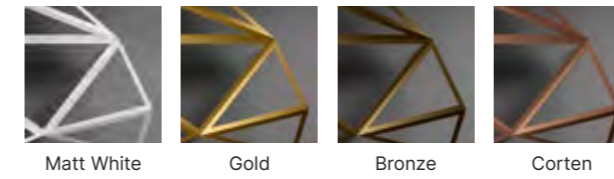

Matt White    Gold    Bronze    Corten

Starlight collection



STARLIGHT PENDANT  
208

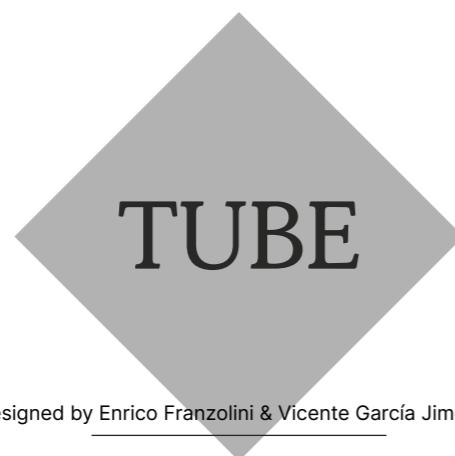

designed by Enrico Franzolini & Vicente García Jimenez

**Enlightened synthesis.  
Available in the ceiling or  
wall hung version, Tube is  
the lighting solution suitable  
for different project design  
and aesthetic requirements:  
two sizes, five finishings  
and a multitude of  
installation options.**

Sintesi illuminata.

Disponibile nella versione a soffitto o a parete, Tube è la soluzione di illuminazione adatta per diverse esigenze progettuali ed estetiche: due misure, cinque finiture e molteplici possibilità di installazione.



WALL/CEILING LAMPS





TUBE ceiling lamps | Black Goffratino lamp with Gold reflector  
 CITY LOUNGE armchair | D05/413 fabric and Oak varnished solid ash wood legs  
 MELBOURNE side table | Fokos Terra porcelain stoneware top and Oak varnished solid ash wood legs

**Its light is punctual, a lamp that is simple in appearance but makes an impact in any space, whether residential or business.**

La sua luce è puntuale, una lampada semplice all'apparenza ma d'impatto in qualsiasi spazio, sia residenziale che business.





Ceiling lamp

TUBE

Ceiling lamp in powder coated aluminium.  
Lampada a soffitto in alluminio verniciato.

6,3W LED  
220-240V  
2700K  
CRI90  
T/fase | DALI/Push dimm

CE IP20 LED 45-60° 880lm MacAdam Step 3 UGR<sub>19</sub>

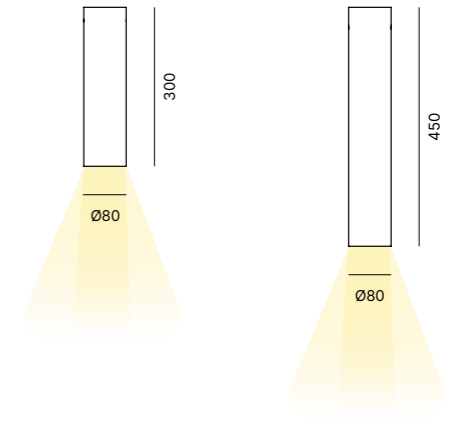

For the icon summary refer to pages 400 - 403 / Per la legenda icone vedere pp. 400 - 403

SHADE FINISH OPTIONS  
FINITURE PARALUME

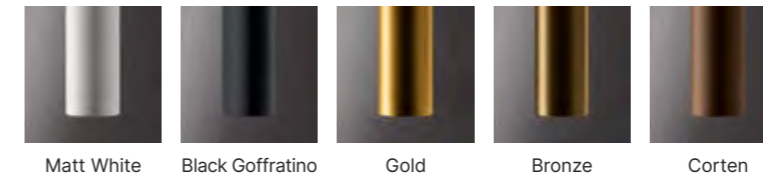

REFLECTOR FINISH OPTIONS  
FINITURE RIFLETTORE



Tube collection

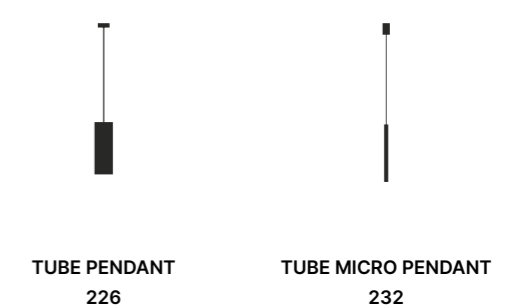



Wall lamp

TUBE

Wall lamp in powder coated aluminium.  
Lampada a parete in alluminio verniciato.

12,6W LED  
220-240V  
2700K  
CRI90  
T/fase | DALI/Push dimm

CE IP20 LED 45-60° 1760lm MacAdam Step 3 UGR<sub>19</sub>

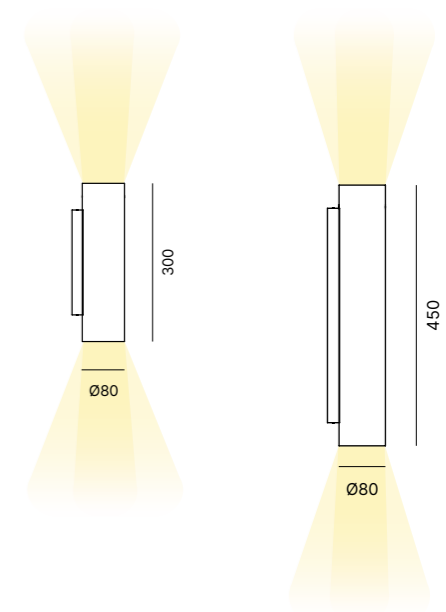

For the icon summary refer to pages 400 - 403 / Per la legenda icone vedere pp. 400 - 403

SHADE FINISH OPTIONS  
FINITURE PARALUME

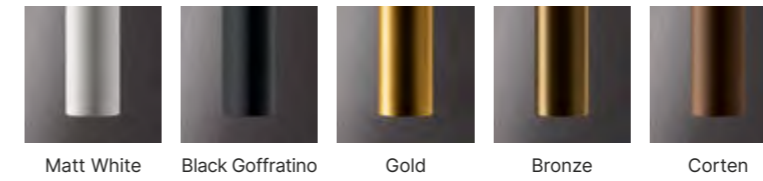

REFLECTOR FINISH OPTIONS  
FINITURE RIFLETTORE



Tube collection

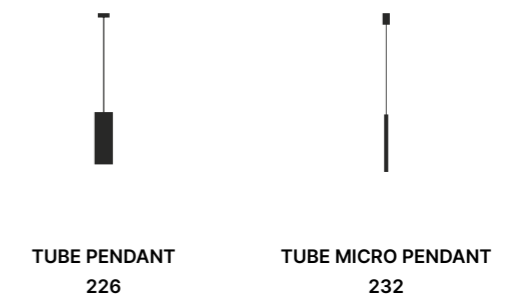

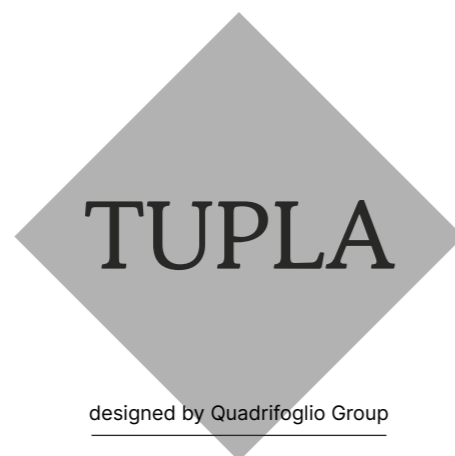

**Pure light.**  
**Tupla is the wall lamp for residential and hospitality settings: its simple and succinct shape, combined with the warm and adjustable light, creates a unique ambience every time.**

**Pura luce.**  
**Tupla è la lampada a parete ideale per ambienti residenziali e di hospitality: la forma semplice e sintetica, unita alla luce calda e regolabile, crea un'atmosfera ogni volta unica.**

  
WALL/CEILING LAMPS







## Wall lamp

## TUPLA

Wall lamp with polished aluminium frame and matt methacrylate shade.

Lampada a parete con struttura in alluminio lucidato e paralume in metacrilato opalino.

**Tupla 28**

2X4,3W LED  
800 lm  
220-240V  
2700K  
CRI80  
T/fase

**Tupla 40**

2X8,7W LED  
1600 lm  
220-240V  
2700K  
CRI80  
T/fase

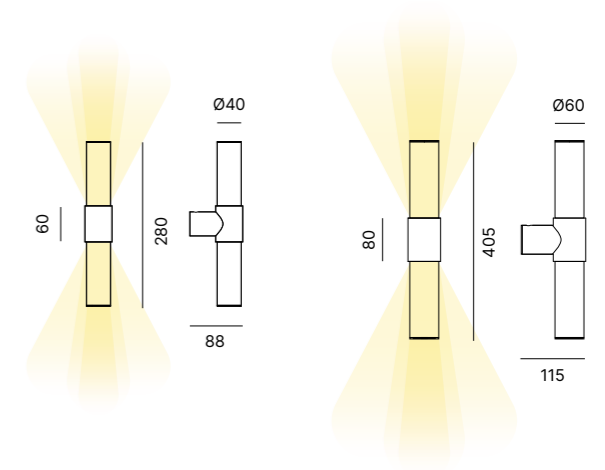

CE IP44   UGR<sub>19</sub>

For the icon summary refer to pages 400 - 403 / Per la legenda icone vedere pp. 400 - 403

SHADE FINISH OPTIONS  
FINITURE PARALUME

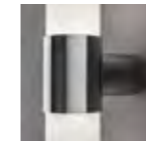

Polished  
aluminium

# TURN ME!

designed by Marta Laudani & Marco Romanelli

**Changeable personality.  
Turn me! is the wall lamp  
that innovates the concept  
of lighting: thanks to its  
rotating structure, light  
can be directed any way,  
according to needs.**

**Personalità mutevole.  
Turn me! è la lampada a parete che innova  
il concetto di illuminazione: grazie alla sua  
struttura rotante, si può direzionare la luce a  
piacimento a seconda delle necessità.**

  
WALL/CEILING LAMPS



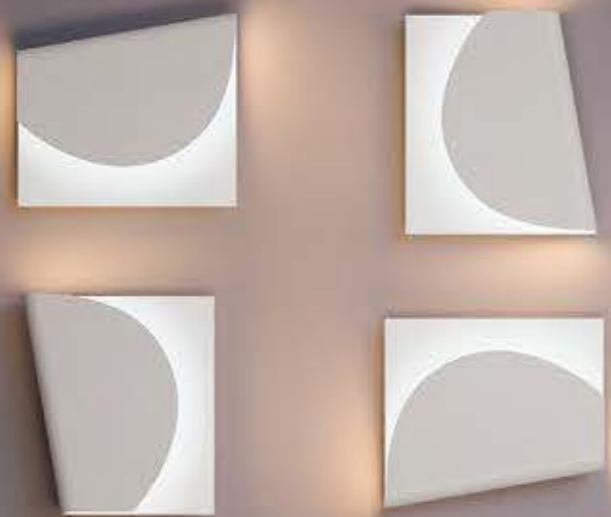



### Wall lamp

### TURN ME!

Wall lamp in powder coated aluminium.  
Lampada a parete in alluminio verniciato.

8W LED  
220-240V  
2700K  
CRI80  
T/fase

CE IP20   1300lm UGR<sub>19</sub>

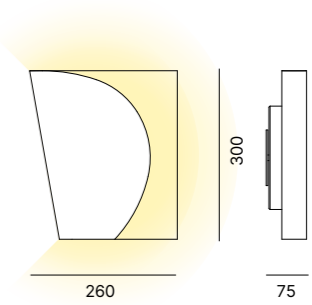

For the icon summary refer to pages 400 - 403 / Per la legenda icone vedere pp. 400 - 403

#### LAMP FINISH OPTIONS FINITURE LAMPADA

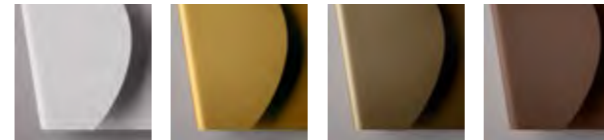

Matt White

Gold

Bronze

Corten

#### DETAILS DETTAGLI



## Architectural Lighting

**Minimalistic ambience. Comfort, authoritativeness, refinement, completeness: the sensations given off by any setting are all a matter of light. Architectural systems are modular and configurable, for complete freedom of design in living and professional settings.**

Atmosfere minimal.  
Accoglienza, autorevolezza, raffinatezza, completezza:  
le sensazioni che restituisce uno spazio sono una  
questione di luce. I sistemi architettonici sono modulabili  
e componibili, per una completa libertà progettuale in  
contesti living e professionali.



## Family Index

Architectural Lighting



CARTESIO

AUROOM  
BOND  
GLOBE  
MASTER  
SPOTLIGHT  
SLASH

# CARTESIO

designed by Moreno De Giorgio

310

311





**Cartesio characterises settings with discretion and conviction. It consists of a slender metal profile, dimmable led lights and a selection of different lamps for use as accessories, in order to create a more or less rich composition.**

Cartesio caratterizza gli ambienti con discrezione e decisione: è formato da un profilo sottile in metallo, luci a led dimmerabili e diverse tipologie di lampade da utilizzare come accessori per rendere più o meno ricca o luminosa la composizione tra cui scegliere.





**Designed to respond to a multitude of style requirements, Cartesio can be installed horizontally or vertically, wall or ceiling mounted, thanks to a series of combinable joints.**

Progettato per rispondere a molteplici esigenze di stile, Cartesio si può installare sia in orizzontale, che in verticale, a parete e a soffitto, grazie a una serie di giunzioni combinabili.



**Light points can be positioned along the track of Cartesio, such as spotlights, spheres, bars and other decorative elements, to personalise the lighting of settings big and small.**

È possibile posizionare lungo il binario di Cartesio punti luce quali faretti, sfere, barre e altri elementi decorativi, per personalizzare l'atmosfera luminosa di ambienti di ampie e piccole dimensioni.

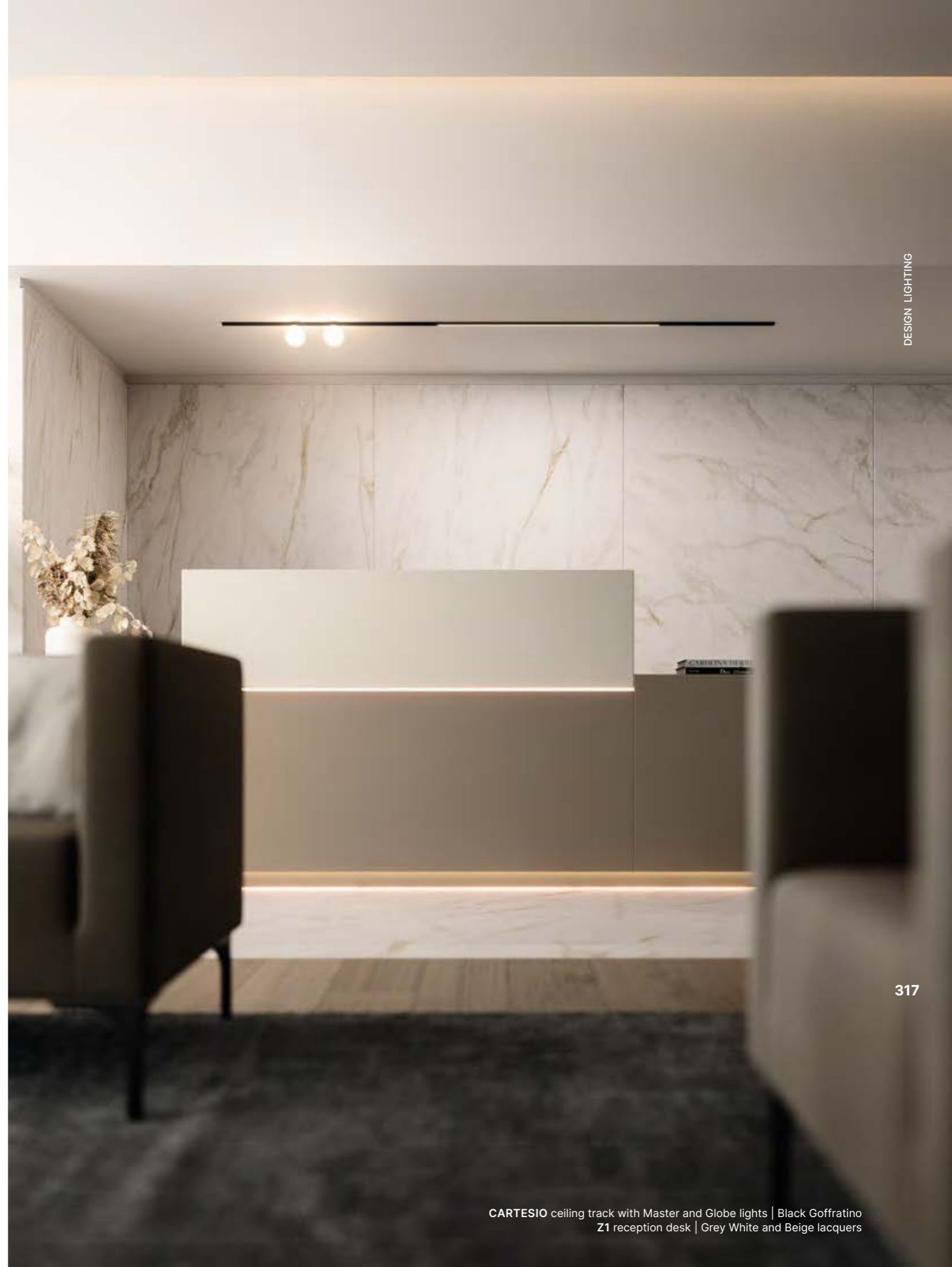
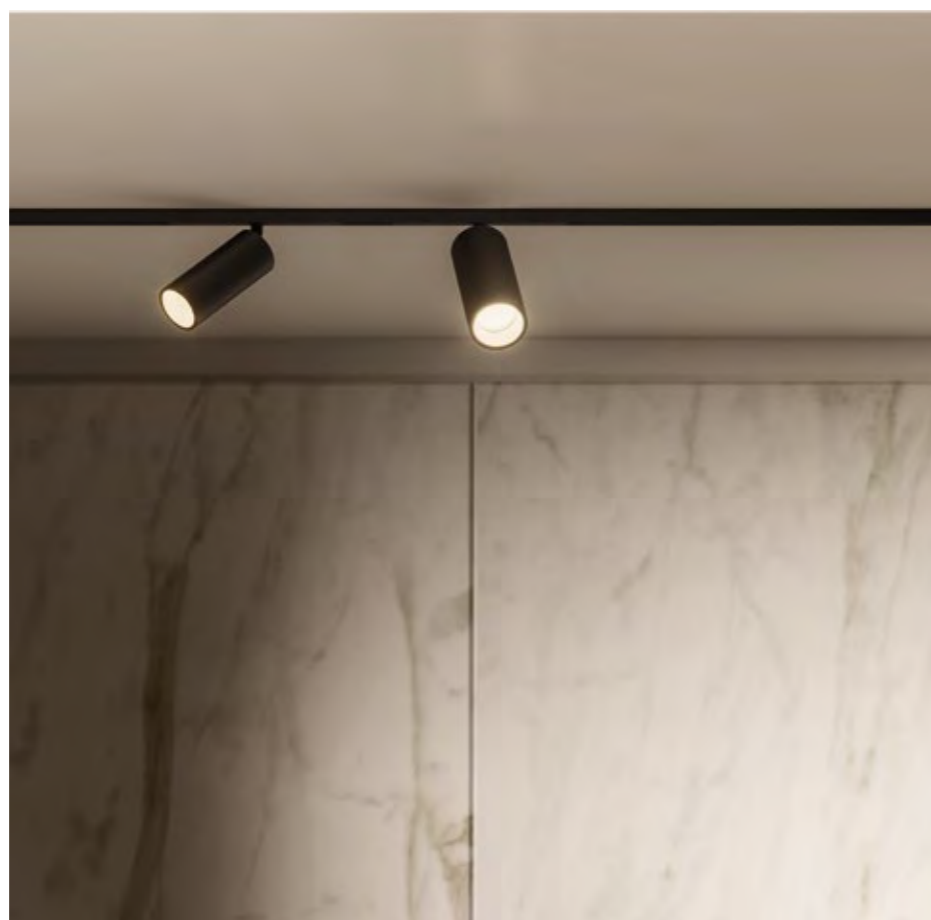



**The Cartesio system marks the discovery of a new frontier of lighting: different options are available to direct light, including continuous, concentrated, diffuse or radiating forms, for tailored visual comfort.**

Con il sistema Cartesio nasce una nuova frontiera dell'illuminazione: è possibile scegliere tra diverse opzioni per direzionare la luce, tra cui continua, concentrata, diffusa o radente, per un comfort visivo su misura.

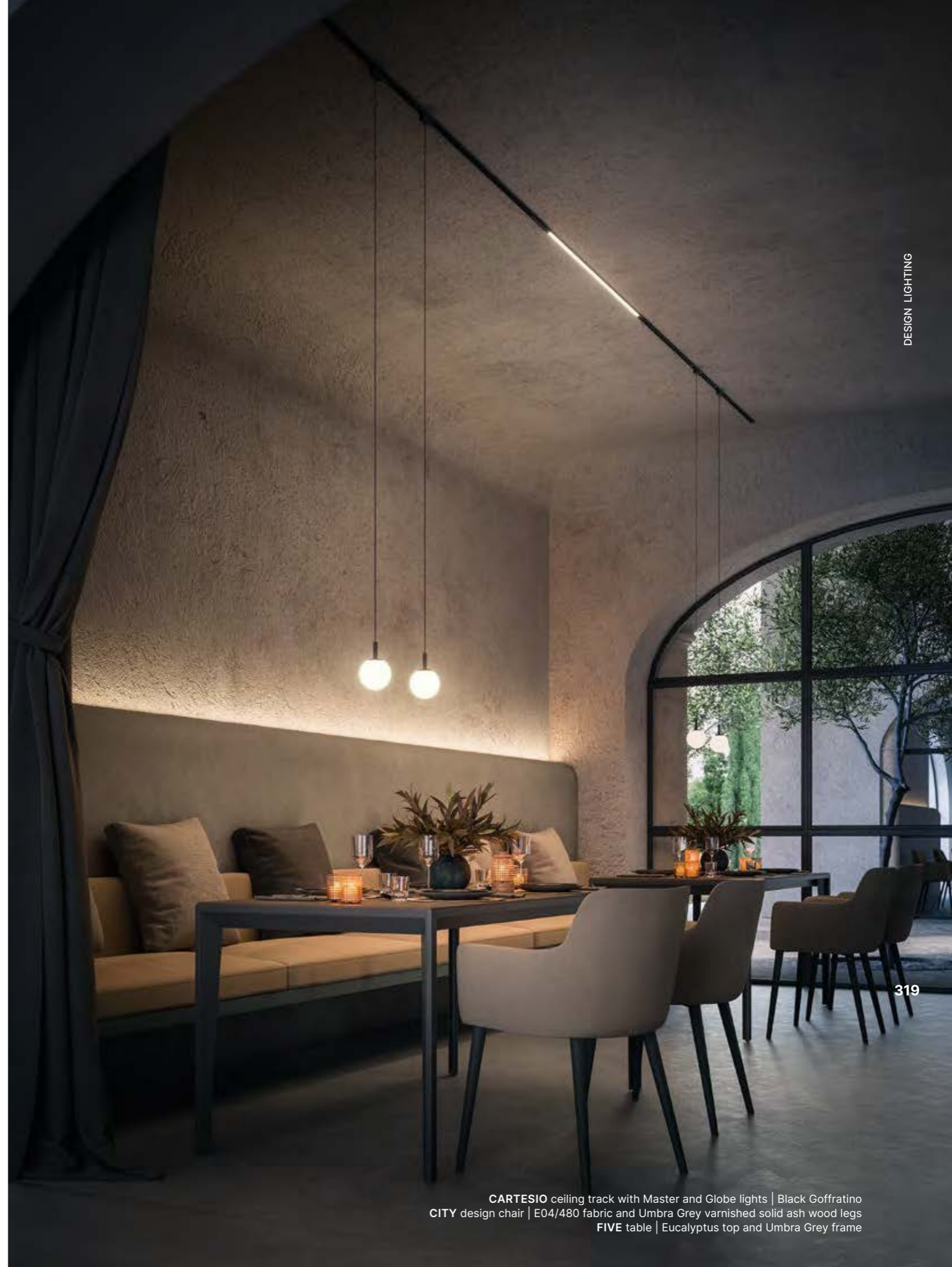



**Designed to provide elegant and functional lighting in a variety of settings, Cartesio guarantees the visual well-being of people, even in business spaces, encouraging concentration and productivity.**

Progettato per illuminare diversi tipi di contesti in modo elegante e funzionale, Cartesio garantisce il benessere visivo delle persone anche negli spazi business, favorendo concentrazione e produttività.





**Simple, linear, functional, with a strong aesthetic impact and adjustable in line with the intended context: Cartesio can be shaped according to design requirements, offering numerous possibilities for interpretation.**

Semplice, lineare, funzionale, dal forte impatto estetico e modulabile in linea con il contesto di destinazione: Cartesio si lascia plasmare a seconda delle esigenze progettuali, offrendo numerose possibilità di installazione.

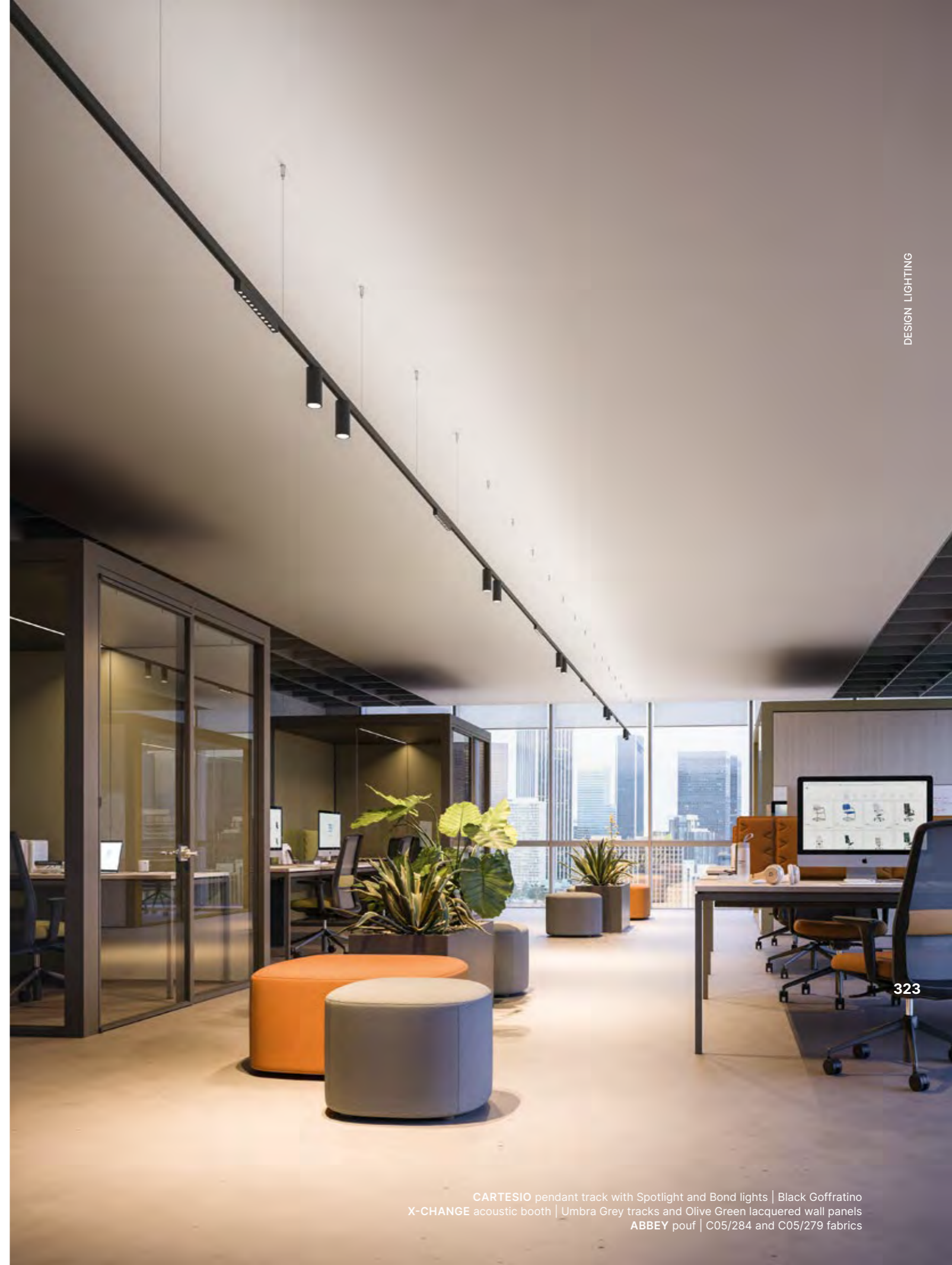



Wall / Ceiling track

CARTESIO

Micro track 48V  
Micro binario 48V

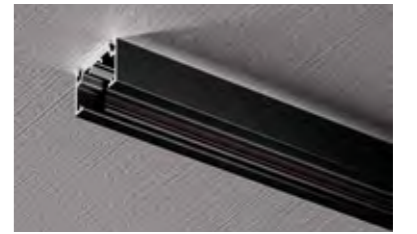
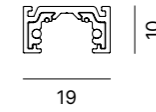

CE IP20

LENGHT / LUNGHEZZA  
1000 - 2000 - 3000 mm

FINISH / FINITURA  
Black Goffratino



For the icon summary refer to pages 400 - 403 / Per la legenda icone vedere pp. 400 - 403

Cartesio wall/ceiling tracklights



1. AUROOM



2. MASTER



3. BOND



4. ADJUSTABLE SPOTLIGHT



5. SLASH



6. GLOBE



7. GLOBE PENDANT

Specifications at pages 328-329

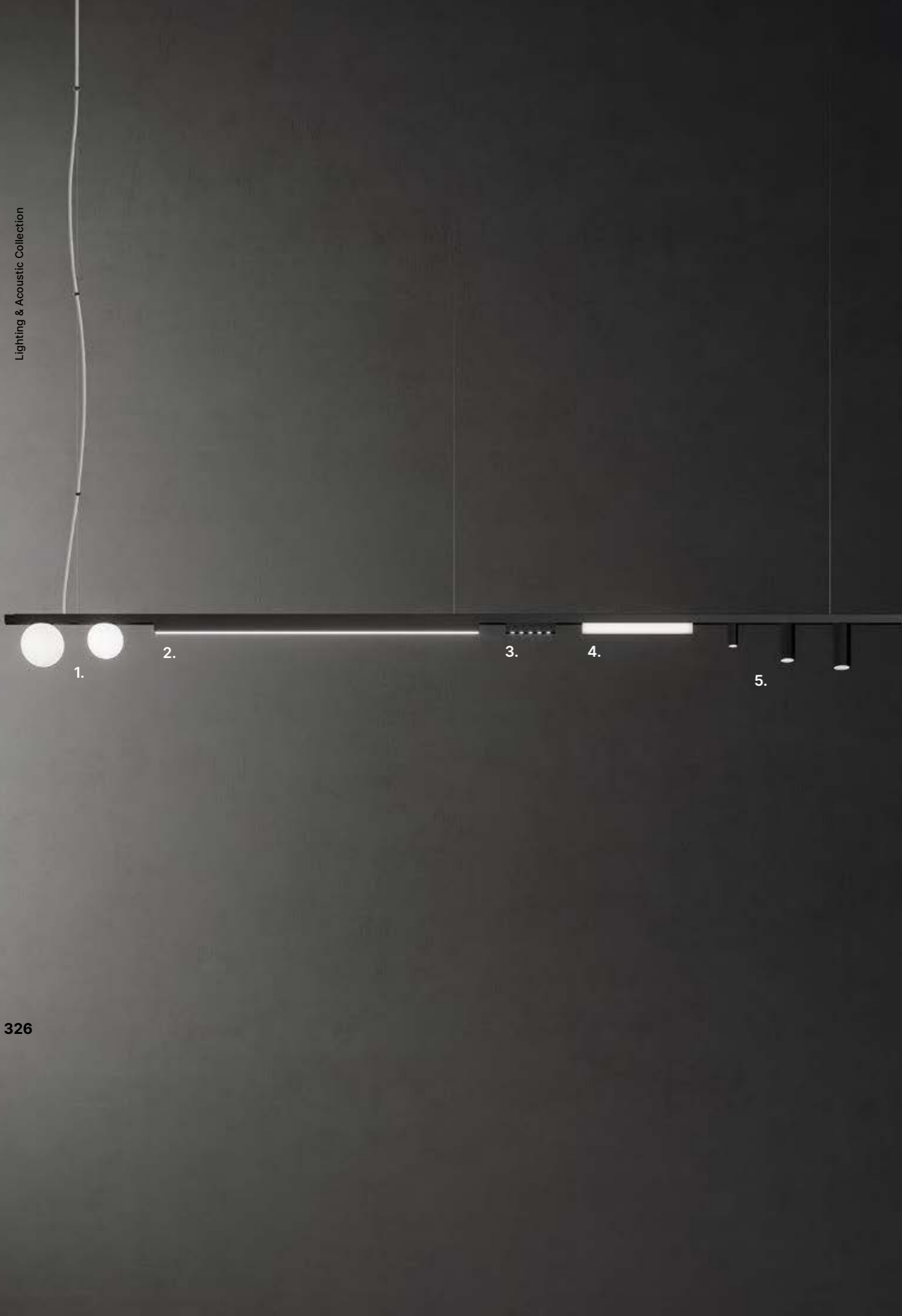

### Pendant track

## CARTESIO

Micro track 48V  
Micro binario 48V

CE IP20

LENGHT / LUNGHEZZA  
1000 - 2000 - 3000 mm

FINISH / FINITURA  
Black Goffratino

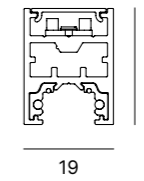

For the icon summary refer to pages 400 - 403 / Per la legenda icone vedere pp. 400 - 403

### Cartesio pendant tracklights



1. GLOBE



2. AUROOM



3. BOND



4. MASTER



5. FIXED SPOTLIGHT

**Auroom**

Straight down light W. 315/915mm  
Lampada lineare diretta L. 315/915 mm

4,9W LED / 14,4W LED  
CRI90  
600 lm / 1800 lm  
2700K / 3000K

CE IP20 LED 48V MacAdam Step 3 UGR<sub>19</sub>



**Master**

Straight diffused light W. 315/915mm  
Lampada lineare diffusa L. 315/915 mm

4,9W LED / 14,4W LED  
CRI90  
600 lm / 1800 lm  
2700K / 3000K

CE IP20 LED 48V MacAdam Step 3 UGR<sub>19</sub>



**Slash**

Triangular lamp W. 314mm  
Lampada triangolare L. 314mm

4,9W LED  
CRI90  
600 lm  
2700K / 3000K

CE IP20 LED 48V MacAdam Step 3 UGR<sub>19</sub>



**Bond**

5 or 10-lights spotlight  
Faretto 5 o 10 luci

5,7W LED / 11,1W LED  
CRI90  
525 lm / 1050 lm  
2700K / 3000K

CE IP20 LED 48V 25-60° UGR<sub>19</sub>



**Spotlight**

Adjustable spotlights Ø 30/43/53 mm  
Faretti orientabili Ø 30/43/53 mm

3,2W / 10,6W / 13,9W - CRI90  
177 lm / 720 lm / 1065 lm  
2700K / 3000K

CE IP20 LED 48V 15-30° 15-30° MacAdam Step 3 UGR<sub>19</sub>



**Spotlight**

Fixed spotlights Ø 30/43/53 mm  
Faretti fissi Ø 30/43/53 mm

3,2W / 10,6W / 13,9W - CRI90  
177 lm / 720 lm / 1065 lm  
2700K / 3000K

CE IP20 LED 48V 15-30° MacAdam Step 3 UGR<sub>19</sub>



**Globe**

Round lamp Ø 100/120 mm  
Lampada sfera Ø 100/120 mm

3W LED  
CRI90  
420 lm  
2700K / 3000K

CE IP20 LED 48V UGR<sub>19</sub>



**Globe**

Round pendant lamp Ø 100/120 mm  
Lampada sfera a sospensione Ø 100/120 mm

3W LED  
CRI90  
420 lm  
2700K / 3000K

CE IP20 LED 48V UGR<sub>19</sub>

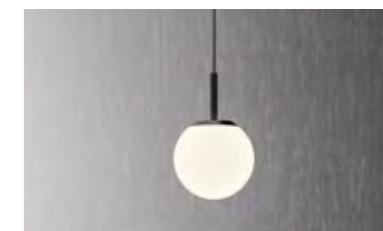

## Office Lighting

**Light projects.**  
**Responding to the operative and executive needs of an office means being able to skilfully combine the brightness, tonality and position of lights. Office lamps take centre stage as fundamental elements of visual comfort for people.**

Progetti luminosi.

Rispondere alle esigenze operative e di rappresentanza di un ufficio significa combinare con sapienza intensità, tonalità e collocazione della luce. Le lampade da ufficio diventano protagoniste insostituibili del comfort visivo delle persone.



## Family Index

Office Lighting

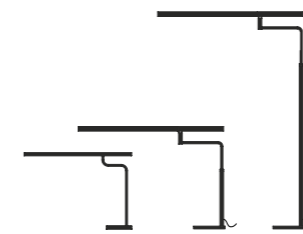

### MINISTICK

MICROSTICK TABLE - 332  
 MINISTICK TABLE - 338  
 MINISTICK FLOOR - 344



### MORE

MORE FLOOR - 350

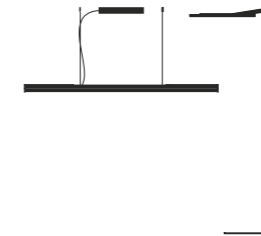

### FLY

FLY FLOOR - 356  
 FLY PENDANT - 362



### EUSTRESS

EUSTRESS PENDANT - 368



### LIGHTSOUND

TRIANGLE PENDANT LAMP  
 EASY PENDANT LAMP  
 CLOAK ACOUSTIC PANEL  
 PETAL ACOUSTIC PANEL  
 374 - 397

# MICROSTICK

designed by Moreno De Giorgio

**Compact functionality.  
Efficient and minimal,  
Microstick is the desk  
lamp par excellence, at  
home or in the office. The  
soft led light is adjustable  
with a touch sensor for  
superlative comfort.**

Funzionalità compatta.

Efficiente e minimale, Microstick è la lampada da scrivania per eccellenza, a casa o in ufficio. La luce soft a led è regolabile con un sensore touch per il massimo comfort.



TABLE LAMPS

334

335



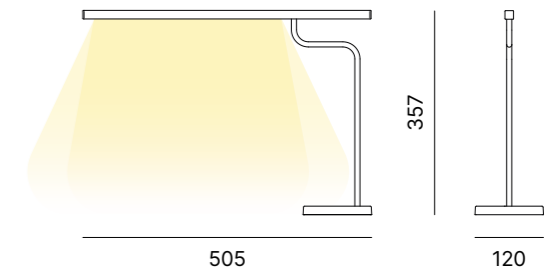

Table lamp

MICROSTICK

Table lamp in powder coated aluminium.  
Lampada da tavolo in alluminio verniciato.

15,3W LED  
220-240V  
3000K  
CRI80  
Touch Dimm



CE IP20   800lm UGR<sub>19</sub>

For the icon summary refer to pages 400 - 403 / Per la legenda icone vedere pp. 400 - 403

LAMP FINISH OPTIONS  
FINITURE LAMPADA



Matt White

Black  
Goffratino

DETAILS  
DETTAGLI



Touch dimmer  
function

Ministick collection

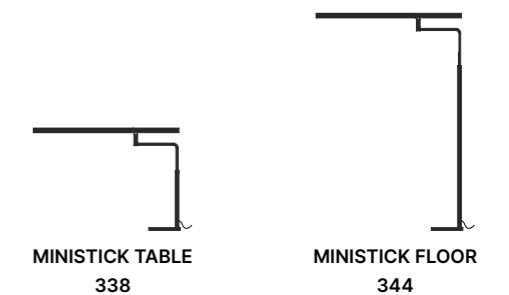

MINISTICK TABLE  
338

MINISTICK FLOOR  
344

# MINISTICK

designed by Moreno De Giorgio

**Directions of light.  
The essential design of  
Ministick makes it perfect  
for versatile use, thanks  
to the microprismatic high  
efficiency diffuser and the  
position adjustment of this  
table lamp.**

Direzioni di luce.

Il design essenziale di Ministick si presta a un utilizzo versatile, grazie al diffusore microprismatico ad alta efficienza e alla possibilità di regolare la posizione di questa lampada da tavolo



TABLE LAMPS



340

341

MINISTICK table lamps | Black Goffratino  
X3 bench desk | Oak top, White and Oak frame  
DIADE ROCK office chair | C05/284 fabric and White frame

Table lamp

MINISTICK

Table lamp in powder coated aluminium. Brushed anodized aluminium shade and high-efficiency microprismatic diffuser.  
 Lampada da tavolo in alluminio verniciato. Paralume in alluminio spazzolato anodizzato e diffusore microprismatico ad alta efficienza.

21,6W LED  
 110-240V  
 3000K  
 CRI90  
 Touch Dimm

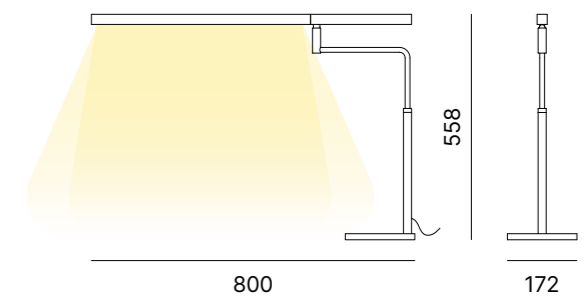

CE IP20 [square icon] [LED icon] 24V 2395lm [MacAdam Step 3 icon] UGR<sub>19</sub>

For the icon summary refer to pages 400 - 403 / Per la legenda icone vedere pp. 400 - 403

LAMP FINISH OPTIONS  
 FINITURE LAMPADA



Matt White      Black Goffratino

DETAILS  
 DETTAGLI



±170° rotation      ±45° rotation      Touch dimmer function



Ministick collection

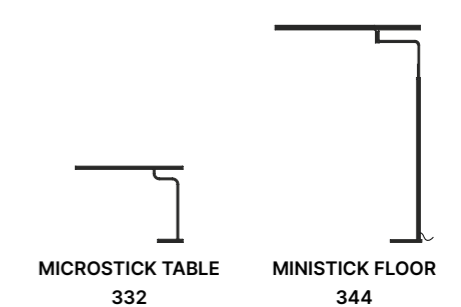

# MINISTICK

designed by Moreno De Giorgio

**Slender brightness.  
Technology and beauty  
meet in the Ministick floor  
lamp: the simple and elegant  
lines enclose a strong and  
determined character and  
are suitable for a world of  
different configurations.**

Slanciata luminosità.

Tecnologia e bellezza si incontrano nella lampada da terra  
Ministick: le linee semplici ed eleganti racchiudono un carattere  
forte e deciso e si prestano a un mondo di configurazioni diverse.



FLOOR LAMPS



346

347

MINISTICK floor lamps | Black Goffratino  
ACCORD high-back sofa | P01/095 leather and C05/280 fabric, Umbrà Grey legs  
T05 coffee table | Eucalyptus

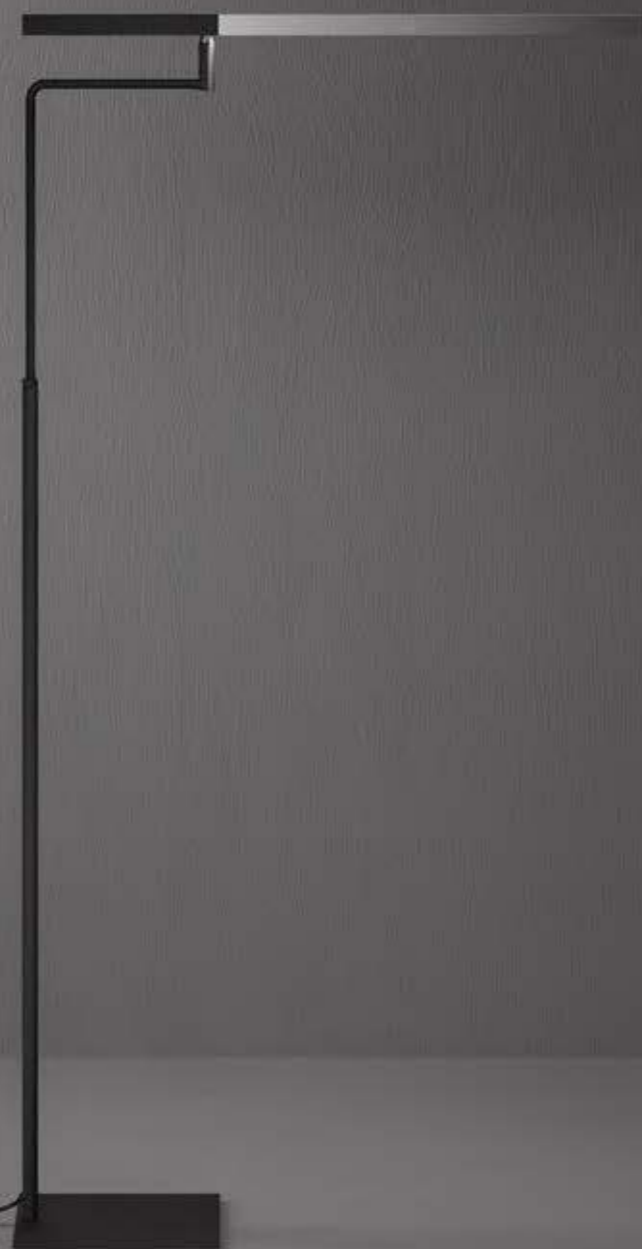



## Floor lamp

## MINISTICK

Floor lamp in powder coated aluminium. Brushed anodized aluminium shade and high-efficiency microprismatic diffuser.

Lampada da terra in alluminio verniciato. Paralume in alluminio spazzolato anodizzato e diffusore microprismatico ad alta efficienza.

21,6W LED  
110-240V  
3000K  
CRI90  
Touch Dimm

CE IP20   24V 2395lm  MacAdam Step 3 UGR<sub>19</sub>

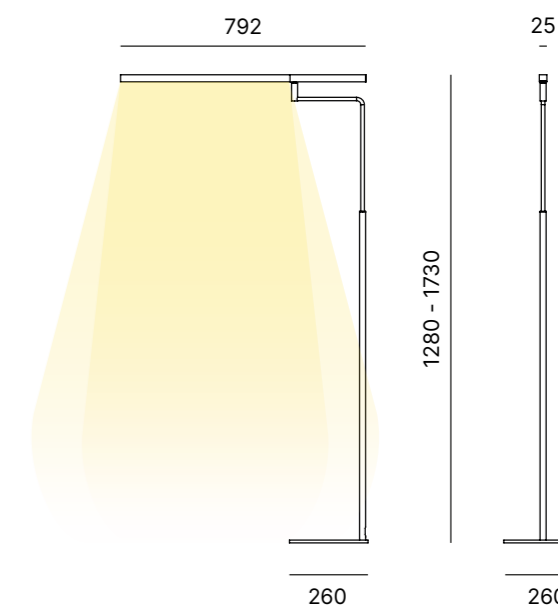

For the icon summary refer to pages 400 - 403 / Per la legenda icone vedere pp. 400 - 403

LAMP FINISH OPTIONS  
FINITURE LAMPADA

Matt White

Black  
GoffratinoDETAILS  
DETTAGLI

±170° rotation

±45° rotation

Touch dimmer  
function

## Ministick collection

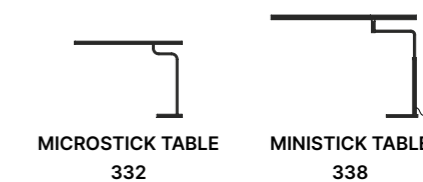
MICROSTICK TABLE  
332MINISTICK TABLE  
338



designed by Moreno De Giorgio

**Measured forms.  
Logic, power and linearity:  
in More proportions,  
technology and attention  
to details bring to life  
an essential and high-  
performance lamp,  
ideal for offices with a  
contemporary look.**

Forme misurate.

Logica, potenza e linearità: in More le proporzioni, la tecnologia e la cura dei dettagli danno vita a una lampada essenziale e performante, ideale per gli uffici dal look contemporaneo.



FLOOR LAMPS



MORE floor lamp | Matt White  
OXYGEN office chair | R06/230 mesh and C05/290 fabric, White frame  
X3 bench desk | White and Oak legs, Oak top





354

## Floor lamp

MORE

Floor lamp in powder coated aluminium.  
Lampada da terra in alluminio verniciato.

More 8	More 12	More 16
82W LED	133W LED	149W LED
8826 lm	13760 lm	18694 lm
110-240V	110-240V	110-240V
3000K	3000K	3000K
CRI90	CRI90	CRI90
Touch Dimm	Touch Dimm	Touch Dimm

CE IP20   24V  MacAdam Step 3 UGR<sub>19</sub>

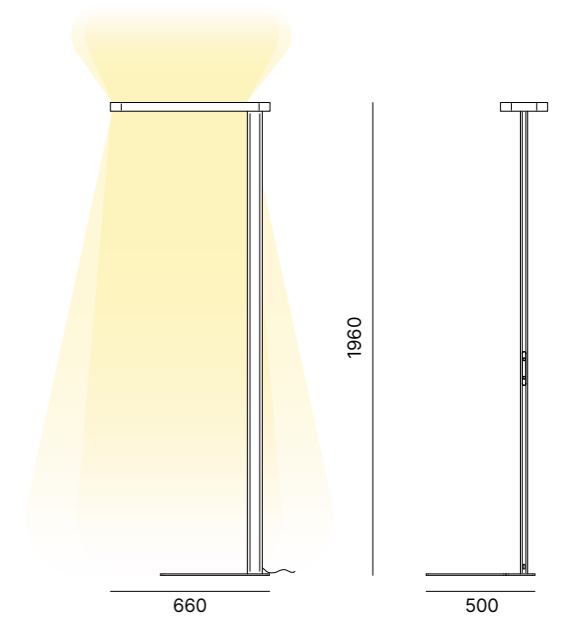

DESIGN LIGHTING

For the icon summary refer to pages 400 - 403 / Per la legenda icone vedere pp. 400 - 403

LAMP FINISH OPTIONS  
FINITURE LAMPADA



Matt White

Black  
goffratino

DETAILS  
DETTAGLI

Touch dimmer  
function

355



**Sophisticated lightness.  
Fly stands out for its  
aerodynamic silhouette and  
fluid design: a floor lamp  
that ensures a characteristic  
and enveloping light, ideal  
for workspaces with a  
refined soul.**

**Sofisticata leggerezza.  
Fly si distingue per la silhouette aerodinamica e il design fluido:  
una lampada da terra che assicura una luce caratteristica e  
avvolgente, ideale per gli spazi di lavoro dall'animo ricercato.**

356



FLOOR LAMPS



357

FLY floor lamp | Matt White  
X3 desk | White top and legs  
DIADE ROCK office chair | C05/290 fabric and White frame





FLY floor lamp | Matt White

## Floor lamp

## FLY

Floor lamp in powder coated aluminium.  
Lampada da terra in alluminio verniciato.

Fly 8	Fly 12	Fly 16
88W LED	114W LED	154W LED
8978 lm	12653 lm	18778 lm
110-240V	110-240V	110-240V
3000K	3000K	3000K
CRI90	CRI90	CRI90
Touch Dimm	Touch Dimm	Touch Dimm

CE IP20   24V  MacAdam Step 3 UGR<sub>19</sub>

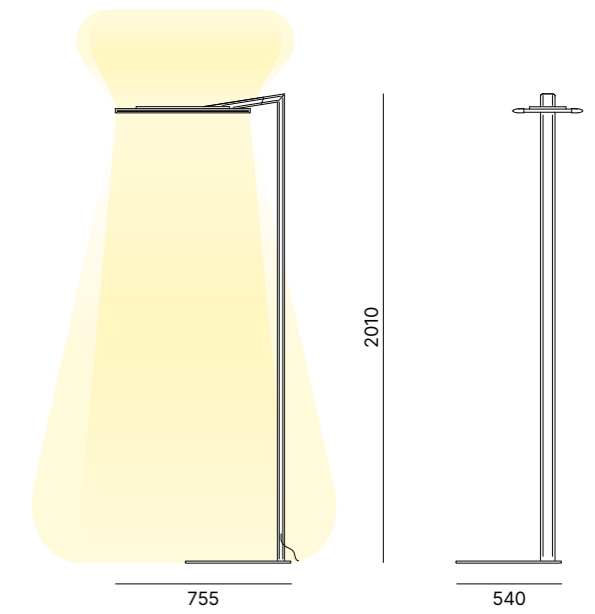

For the icon summary refer to pages 400 - 403 / Per la legenda icone vedere pp. 400 - 403

LAMP FINISH OPTIONS  
FINITURE LAMPADA

Matt White

Black  
goffratinoDETAILS  
DETTAGLITouch dimmer  
function

## Fly collection

FLY PENDANT  
362



**Aerial delicacy.  
Pure lines with an iconic  
style: the Fly suspension  
lamp illuminates design  
environments with a touch  
of shining beauty, thanks to  
the white and thin structure  
that characterises it.**

**Delicatezza aerea.  
Linee pure dallo stile iconico: la lampada a sospensione  
Fly illumina gli ambienti di design con un tocco di  
splendente bellezza, grazie alla struttura bianca e  
sottile che la caratterizza.**



PENDANT LAMPS





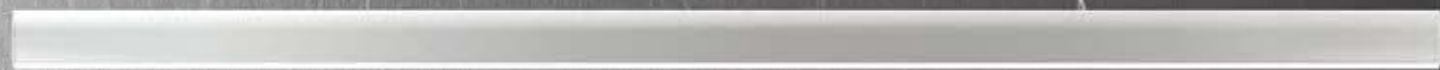

Pendant lamp

FLY

Pendant lamp in powder coated aluminium.  
Lampada a sospensione in alluminio verniciato.

Fly 120	Fly 160
23W LED	27W LED
2438 lm	2862 lm
3000K	3000K
CRI90	CRI90
ON-OFF	ON-OFF

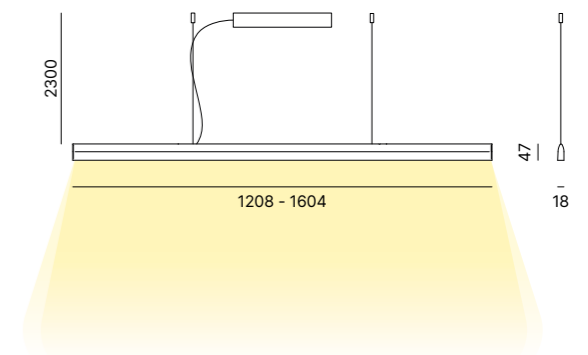

CE IP20 LED 24V MacAdam Step 3 UGR<sub>19</sub>

For the icon summary refer to pages 400 - 403 / Per la legenda icone vedere pp. 400 - 403

LAMP FINISH OPTIONS  
FINITURE LAMPADA

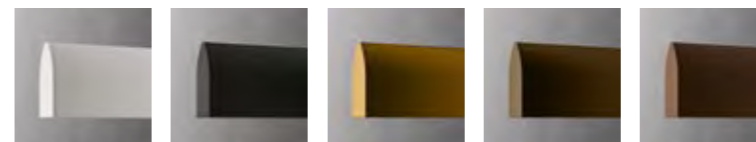

Matt White    Black Goffratino    Gold    Bronze    Corten

Fly collection



FLY FLOOR  
356

# EUSTRESS

designed by Moreno De Giorgio

**Bright paths.**  
Eustress has a minimal and unconventional spirit, defined by its trapezoidal shape: with the latest generation LED and microprismatic diffuser, this lamp creates a contemporary form of lighting.

*Vie luminose.*

Eustress ha uno spirito minimale e anticonformista, definito dalla sua forma trapezoidale: con il led di ultima generazione e il diffusore microprismatico, questa lampada crea una forma contemporanea di illuminazione.



PENDANT LAMPS





370

371

EUSTRESS pendant lamp | Anodized aluminium  
X3 meeting table | Oak top and White legs

## Pendant lamp

Pendant lamp in powder coated aluminium.  
Lampada a sospensione in alluminio verniciato.

Eustress 120	Eustress 160
37W LED	45W LED
3922 lm	4770 lm
3000K	3000K
CRI90	CRI90
ON-OFF   All in one	ON-OFF   All in one

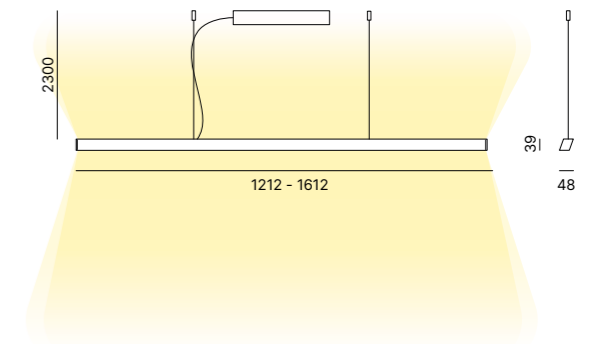

CE IP20 LED 24V MacAdam Step 3 UGR<sub>19</sub>

For the icon summary refer to pages 400 - 403 / Per la legenda icone vedere pp. 400 - 403

LAMP FINISH OPTIONS  
FINITURE LAMPADA

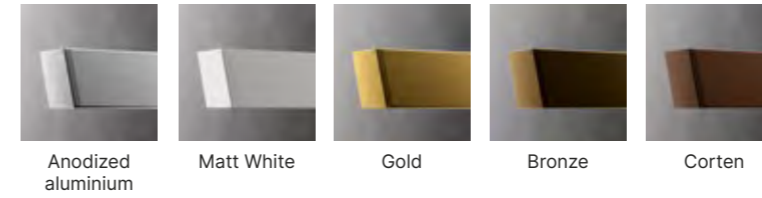

Anodized aluminium

Matt White

Gold

Bronze

Corten

# LIGHTSOUND

designed by Moreno De Giorgio

**Sensory design.  
Visual and auditory  
well-being: this is what  
is perceived in a public  
space furnished with  
Lightsound, the modular  
system of lights and  
sound-absorbing panels.**

Design sensoriale.  
Benessere visivo e uditivo: è ciò che si percepisce in  
uno spazio pubblico arredato con Lightsound, il sistema  
componibile di luci e pannelli fonoassorbenti.



ACOUSTIC ELEMENTS



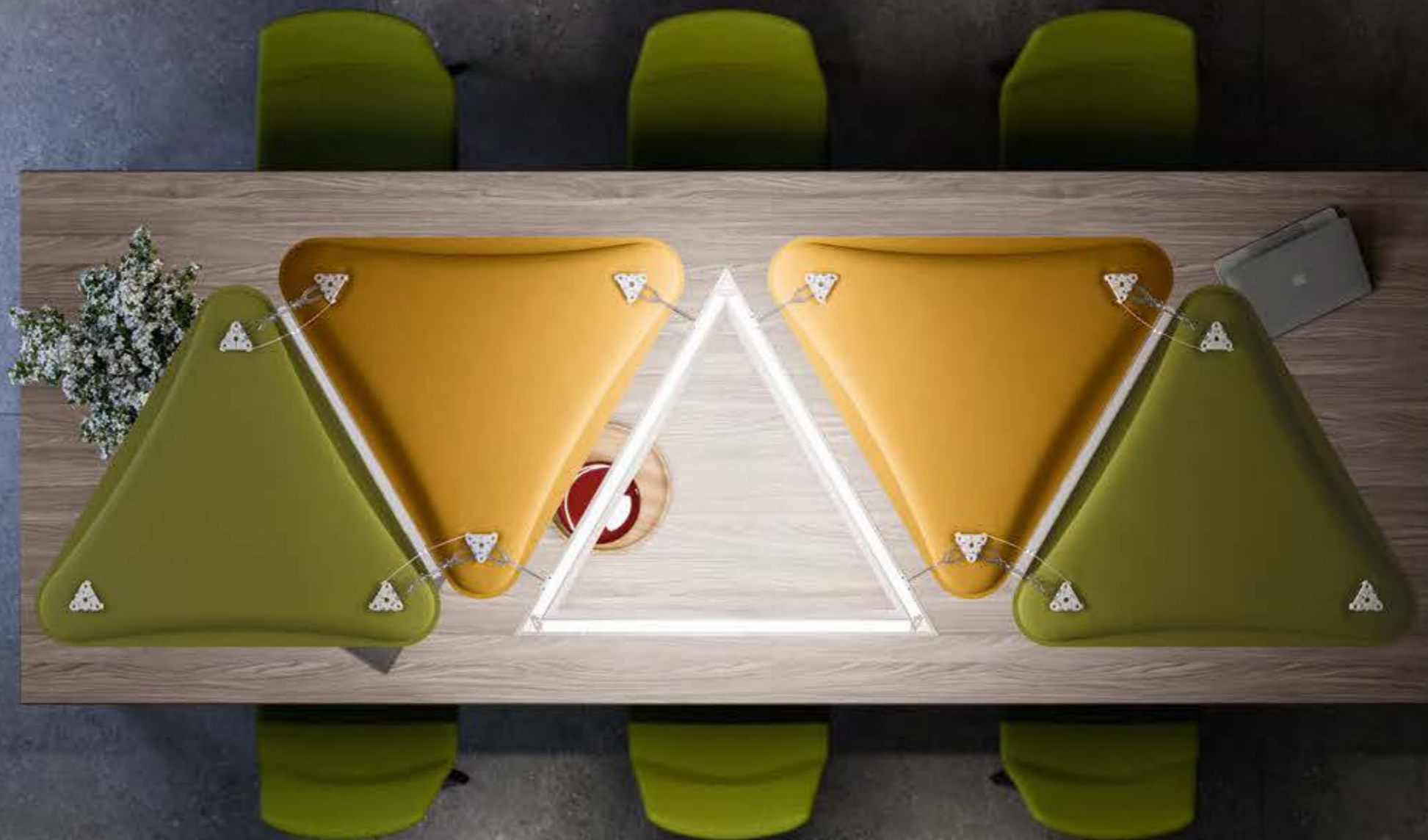

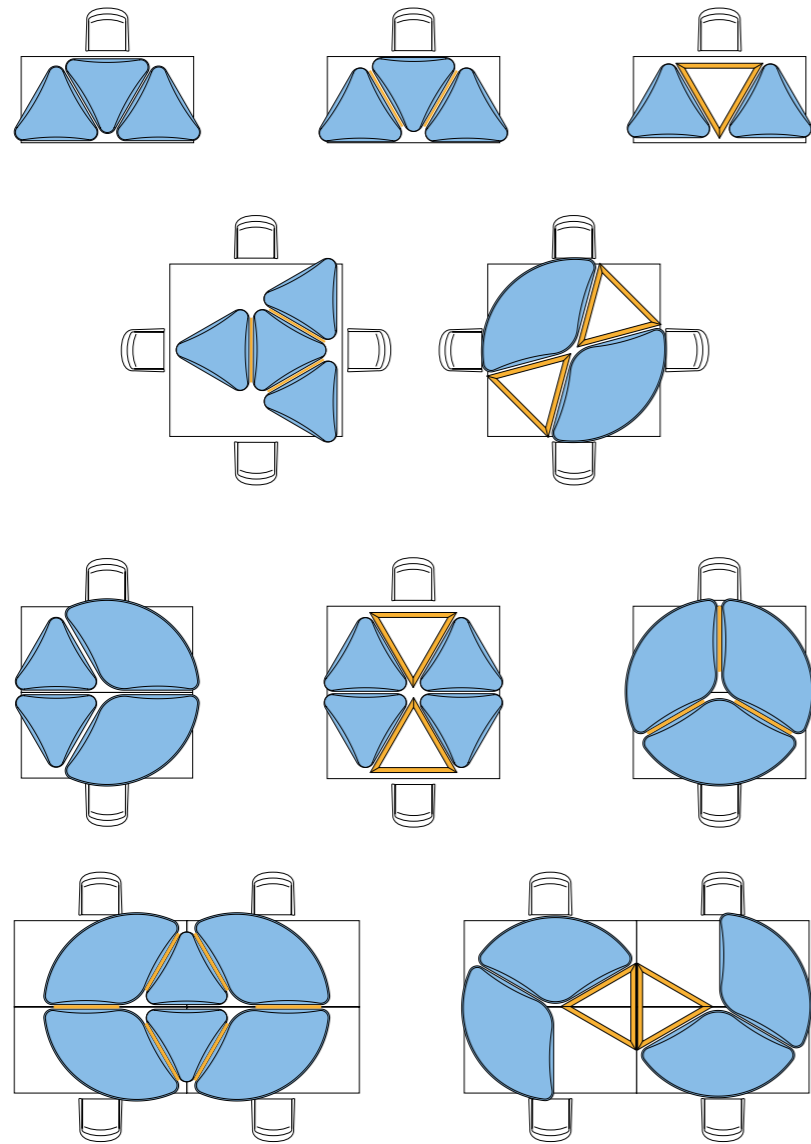

LIGHTSOUND system | B01/012 and B01/023 Cloak and Petal panels, Matt White Triangle lamps  
COVE design chair | White shell and Oak varnished solid ash wood legs  
X3 meeting table | White top, White and Oak frame





382

**Panels are triangular or with a 120° angle and can be matched with Easy and Triangle leds. Lightsound can be installed suspended or wall hung to create shared spaces that are a pleasure to inhabit.**

I pannelli sono triangolari oppure con un angolo di 120° e si possono abbinare ai led Easy e Triangle. Lightsound si installa sia a sospensione sia a parete per creare spazi condivisi piacevoli da vivere.



383





386

**Lightsound can be assembled according to taste and customised with different cover colour options. The panels can also be arranged in the ceiling mounted cascade version, which is ideal for open spaces, hotel lobbies and restaurants.**

Lightsound è componibile a piacimento e personalizzabile nei colori dei rivestimenti. I pannelli si possono disporre anche nella versione a cascata dal soffitto, ideali per open space, sale di hotel e ristoranti.



387

PETAL floor stand with acoustic panels | B01/020, B01/009 and B01/024 fabrics, Matt White frame  
CODE high stool | Oak varnished solid ash wood shell with C05/280 upholstered seat, Chrome frame  
ADO sofa and armchair | M01/590 fabric, Umbra Grey frame and Oak varnished solid ash wood arms







## Pendant lamp

## TRIANGLE

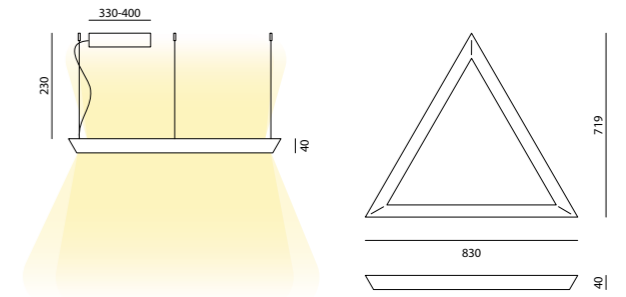
Pendant lamp in anodized or powder coated aluminium.  
Lampada a sospensione in alluminio anodizzato o verniciato.

Down light	Up/Down light
31W LED	49W LED
3286 lm	5194 lm
3000K	3000K
CRI90	CRI90
ON-OFF   All in one	ON-OFF   All in one



CE IP20   24V  MacAdam Step 3 UGR<sub>19</sub>

For the icon summary refer to pages 400 - 403 / Per la legenda icone vedere pp. 400 - 403

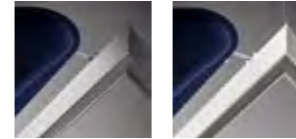
LAMP FINISH OPTIONS  
FINITURE LAMPADAAnodized  
aluminium

Matt White





## Pendant lamp

EASY

Pendant lamp in anodized aluminium.  
Lampada a sospensione in alluminio anodizzato.

11,6W LED  
3000K  
CRI80

CE IP20  24V 1230lm  MacAdam Step 3 UGR<sub>19</sub>

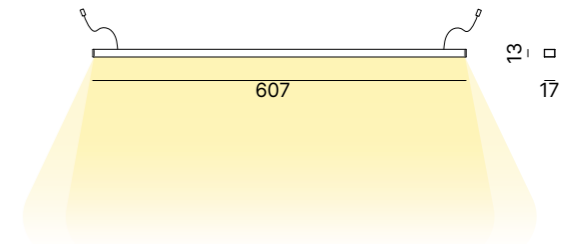

For the icon summary refer to pages 400 - 403 / Per la legenda icone vedere pp. 400 - 403

### LAMP FINISH OPTIONS FINITURE LAMPADA



Anodized aluminium



Acoustic panel

CLOAK

Pendant or wall-mounted sound-absorbing triangular panel, fabric upholstered.  
 Pannello fonoassorbente triangolare, a parete o sospensione, rivestito in tessuto.

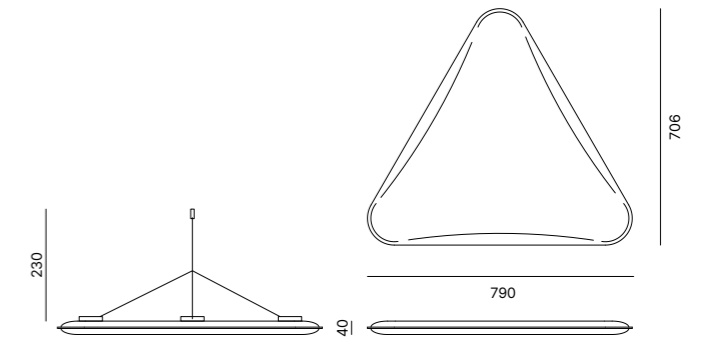

PANELS FINISH OPTIONS  
 FINITURE PANNELLI

B01/008	B01/013	B01/023	B01/012	B01/010	B01/011	B01/019	B01/222
On stock	On stock	On stock	On stock	On stock	On stock	On stock	On stock

DETAILS  
 DETTAGLI

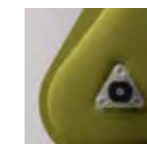

Linking



Acoustic panel

PETAL

Pendant or wall-mounted sound-absorbing 120° panel, fabric upholstered.  
Pannello fonoassorbente 120°, a parete o sospensione, rivestito in tessuto.

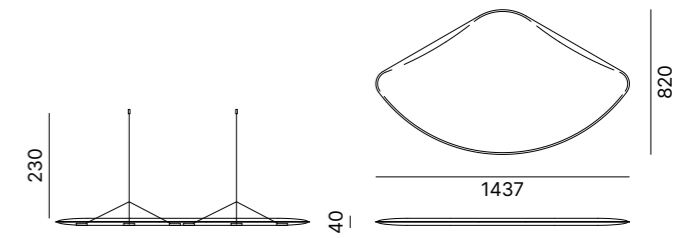

PANELS FINISH OPTIONS  
FINITURE PANNELLI

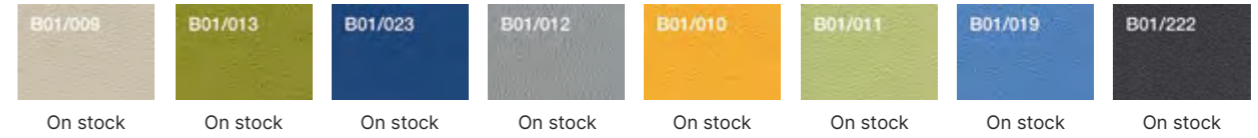

DETAILS  
DETTAGLI

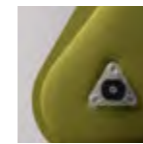

Linking

Acoustic panel

PENDANT CLOAK

Pendant sound-absorbing triangular panel, fabric upholstered.  
Pannelli triangolari fonoassorbenti rivestiti in tessuto, a sospensione verticale.

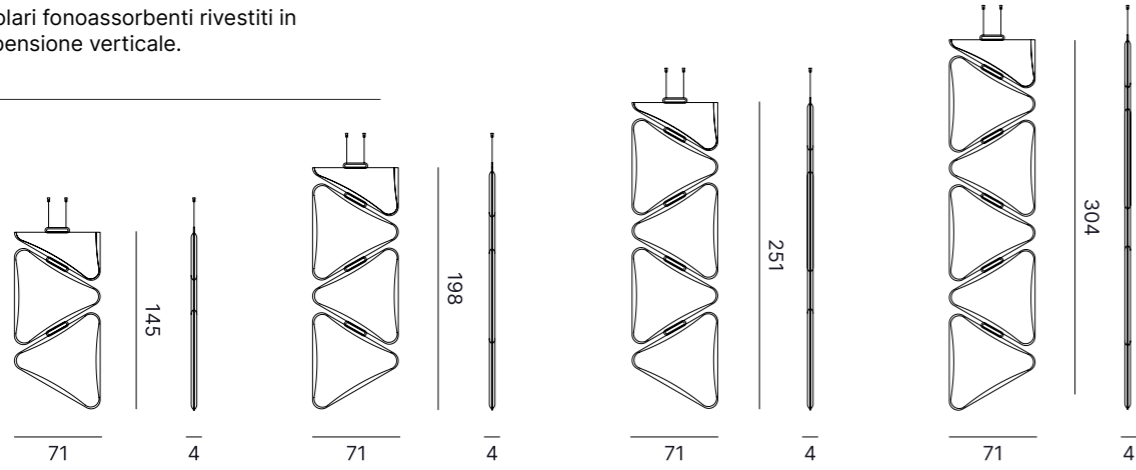

PANELS FINISH OPTIONS  
FINITURE PANNELLI

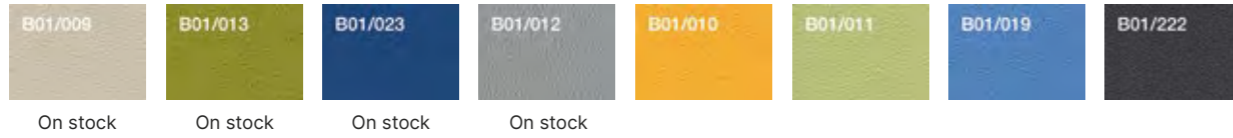

STRUCTURE FINISH OPTIONS  
FINITURE STRUTTURA



Acoustic panel

PETAL FLOOR STAND

Powder coated metal frame. 3 fabric upholstered sound-absorbing panels.  
Piantana in metallo verniciato. 3 pannelli fonoassorbenti 120° rivestiti in tessuto.

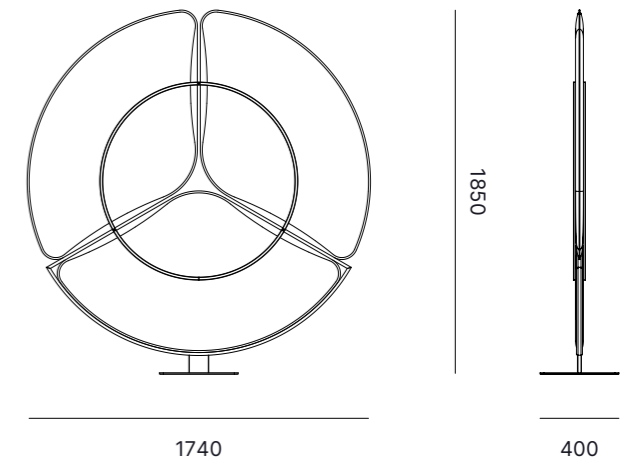

PANELS FINISH OPTIONS  
FINITURE PANNELLI

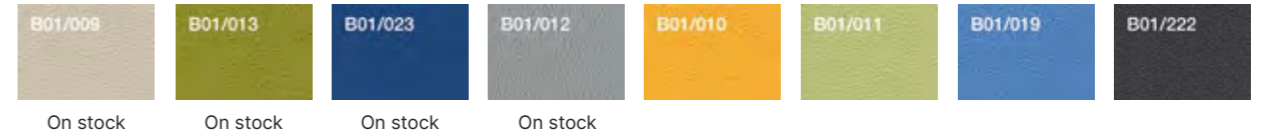

FRAME FINISH OPTIONS  
FINITURE PIANTANA



# SYMBOL LEGEND

## LEGENDA SIMBOLI

**MARKING**  
MARCATURA

**CE** A mark that manufacturers of certain kinds of products must affix to ensure that the goods offered for sale meet the essential safety requirements of the regulations, trading and use of the product in the European Community.

La marcatura CE è un logo che attesta la conformità di un prodotto alla normativa dell'Unione Europea e certifica la rispondenza ai requisiti di sicurezza previsti dalla normativa, quelli di commercializzazione e utilizzo di un prodotto nello spazio economico comunitario.

**PROTECTION DEGREE**  
GRADO DI PROTEZIONE

**IP20** Il codice IP indica il livello di protezione degli involucri contro l'accesso a parti pericolose interne dell'involucro e contro la penetrazione di corpi solidi estranei e di liquidi.

The IP20 rating indicates the enclosures' level of protection against access to dangerous parts inside the enclosure and against penetration by solid foreign objects and liquids.

**INSULATION CLASSES**  
GRADO DI PROTEZIONE

**CLASS I - Earthing**  
Class I insulation is used to identify devices that require an additional safety measure consisting of the connection of the accessible conductive parts to a protective conductor (protective earthing). The latter is connected to the fixed electrical system and prevents the accessible conductive parts to become live in the event of a failure of the main insulation.

**CLASSE I - Messa a terra**  
La classe I di isolamento viene usata per identificare gli apparecchi che necessitano di una misura di sicurezza supplementare costituita dalla connessione delle parti conduttrici accessibili ad un conduttore di protezione (messa a terra di protezione). Quest'ultimo, facendo capo all'impianto elettrico fisso, permette che le parti conduttrici accessibili non vadano in tensione in caso di guasto dell'isolamento principale.

**CLASS II - Double insulation**  
Class II insulation, also called "double-insulated", are designed so that they do not require an earth connection. In Class II products, a single fault cannot cause the user to come into contact with dangerous voltages

**CLASSE II - Doppio isolamento**  
La classe II di isolamento identifica gli apparecchi detti "a doppio isolamento": questi, infatti, sono progettati per non necessitare la connessione della messa a terra. Nei prodotti di classe II un singolo guasto non può causare il contatto con tensioni pericolose da parte dell'utilizzatore.

**CLASS III - Insulation**  
Class III insulation indicates equipment that is powered by battery or by a SELV transformer. The voltage produced, which is less than 25V AC or 60V DC, is low to the point that it is not normally dangerous in the event of contact with the human body. Therefore, Class III equipment must not be provided with protective earthing.

**CLASSE III - Isolamento**  
La classe III di isolamento identifica gli apparecchi che vengono alimentati a batteria o da un trasformatore SELV. La tensione prodotta, inferiore ai 25V AC o 60V DC, è bassa al punto da non essere normalmente pericolosa in caso di contatto con il corpo umano. Pertanto, gli apparecchi di classe III non devono essere provvisti di messa a terra di protezione.

**LUMINOUS FLUX**  
FLUSSO LUMINOSO

**720lm**  
lm (lumen)

Luminous flux is the amount of light emitted by a luminaire and is measured in lumens. Knowing the luminous flux of luminaires helps, from the earliest stages of design, to predimension the lighting so that we can match the atmosphere we want to convey with the finished space.

Il flusso luminoso è la quantità di luce emessa da un apparecchio di illuminazione e si misura in lumen. Conoscere il flusso luminoso degli apparecchi aiuta, fin dalle prime fasi della progettazione, a predimensionare l'illuminazione per poter far coincidere l'atmosfera che vogliamo trasmettere con lo spazio finito. Il flusso luminoso è la quantità di luce emessa da una certa sorgente o apparecchio di illuminazione.

**MACADAM STEP 3**

 The MacAdam index is a key parameter for evaluating the quality of LEDs in order to assess their color constancy and luminous accuracy. To the human eye, color variations within the 3rd step of the MacAdam ellipse are imperceptible.

L'indice MacAdam è un parametro fondamentale per valutare la qualità dei led al fine di valutarne la costanza cromatica e la precisione luminosa. Per l'occhio umano, le variazioni di colore entro il 3° step dell'ellisse MacAdam sono impercettibili.

**COLOR RENDERING INDEX**  
INDICE DI RESA CROMATICA

**CRI90** The Color Rendering Index - CRI is an index ranging from 0 to 100, and it identifies the ability of a light source to faithfully render the colours of an illuminated object.

L'indice di Resa Cromatica (Color Rendering Index - CRI) è un parametro che può variare da 0 a 100, e identifica la capacità di una sorgente luminosa di restituire fedelmente i colori di un oggetto illuminato.

**INSTALLATION**  
APPLICAZIONE

 **Ceiling installation. The direction of the beam is vertical**  
Applicazione a soffitto: la direzione del fascio luminoso è verticale.

 **Wall application. The direction of the beam is lateral**  
Applicazione a parete: la direzione del fascio luminoso è laterale.

**BEAM ANGLE**  
ANGOLO FASCIO LUMINOSO

**15° - 30°** The angle of the light beam refers to the width of the light beam produced by the light body.

L'angolo di fascio luminoso rappresenta l'ampiezza del fascio di luce creato dal corpo luminoso.

**COLOUR TEMPERATURE**  
TEMPERATURA COLORE

**2700K** Colour temperature refers to the tone of white light emitted by a light source. This value is expressed in degrees Kelvin (K) with a scale from 1000 to 12000. The higher the Kelvin number, the whiter or bluer the light will appear.

From 2000K to 3000K identify the temperatures attributable to "warm colors" by their characteristic yellow-orange hue.  
From 3300K to 5300K identify temperatures attributable to "cool white colors"  
From 5300K to 5300K identify temperatures that can be traced back to the white/blueish colors of daylight.

La temperatura di colore si riferisce alla tonalità della luce bianca emessa da una sorgente luminosa. Questo valore viene espresso in gradi Kelvin (K) con una scala da 1000 a 12000. Più alto il numero di Kelvin, più bianca o bluastra apparirà la luce.  
Da 2000K a 3000K = identificano le temperature riconducibili ai "colori caldi" per il loro caratteristico colorito giallo-arancione.  
Da 3300K a 5300K = identificano le temperature riconducibili ai "colori bianchi freddi"  
Da 5300K = identificano le temperature che si riconducono ai colori della luce bianco/bluastra del giorno.

## COMMANDS COMANDI

## LIGHT SOURCE FONTE LUMINOSA

<b>ON/OFF</b>	<b>Control indicating the ON/OFF switch.</b> Comando che identifica l'interruttore di ACCENSIONE/SPEGNIMENTO.
<b>DALI</b>	<b>LIGHT INTENSITY CONTROL</b> CONTROLLO INTENSITÀ LUMINOSA <b>DALI: Digital Addressable Lighting Interface. Communication protocol for managing the switching on/off/dimming of light sources in a timely and reprogrammable manner.</b>  DALI: Digital Addressable Lighting Interface. Protocollo di comunicazione che consente di gestire accensione/spengimento/ dimmerazione delle fonti luminose in modo puntuale e riprogrammabile.
<b>Touch dimm</b>	<b>Command that allows you to control the brightness variation with the touch of the sensor (capacitive).</b> Comando che permette di controllare la variazione della luminosità con il tocco del sensore (capacitivo).
<b>Push dimm</b>	<b>Command that allows you to control the brightness variation by holding down the button.</b> Comando che permette di controllare la variazione della luminosità tenendo premuto il pulsante.
<b>Potenziometer</b> Potenziometro	<b>Command that allows you to control the brightness variation by turning the dimmer clockwise or anticlockwise. (The resistance varies).</b> Comando che permette di controllare la variazione della luminosità ruotando il dimmer in senso orario o antiorario. (Varia la resistenza).
<b>0-10V/1-10V</b>	<b>Command that allows you to control the brightness variation by turning the dimmer clockwise or anticlockwise. (The voltage varies).</b> Comando che permette di controllare la variazione della luminosità ruotando il dimmer in senso orario o antiorario. (Varia la tensione).
<b>Phase chop</b> Taglio di fase	<b>Command that allows you to control the brightness variation by turning the dimmer clockwise or anticlockwise. (The input voltage varies).</b> Comando che permette di controllare la variazione della luminosità ruotando il dimmer in senso orario o antiorario. (Varia la tensione di ingresso).

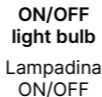
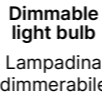
	<b>Indica che la fonte luminosa è a tecnologia LED.</b> It indicates that the light source is LED
	<b>This symbol indicates that it is impossible to adjust the light intensity of the bulb.</b> E' il simbolo che indica l'impossibilità di regolare l'intensità luminosa della lampadina
	<b>This symbol indicates the possibility of adjusting the light intensity of the bulb.</b> E' il simbolo che indica la possibilità di regolare l'intensità luminosa della lampadina.
<b>UGR<sub>L</sub></b>	<b>The UGR is the unified index for the evaluation of direct glare from the lighting system.</b> L'UGR è l'indice unificato per la valutazione dell'abbagliamento diretto derivante dall'impianto di illuminazione.

## SOCKET-PLUG PRESA-SPINA

### SOCKET-PLUG PRESA-SPINA



Type C - EU 2 Poli CEE 7/16

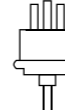

Type G - GRB 3 Poli

### SUPPLY ALIMENTAZIONE

24V

220/240V

110/240V

Product Design  
**Quadrifoglio Group R&D Dept.**

Project Direction & Coordination  
**Quadrifoglio Group Marketing & Communication Dept.**

Creative Direction  
**Willy Dalto**

Graphic Design  
**Federica Mattietto**

Images  
**Nudesign, Udine**

Color Separation & Print  
**Sincromia, Pordenone**  
January 2024 - Ed.01

**Cod. LI0CLA22**

Discover our Designers and Partners



